

POWERBREEZ

New Generation Fan Coils

Biddle



AN EVOLUTION IN FAN COILS

Powerbreez incorporates a number of ground-breaking engineering and design achievements, including the Patented Revolutionary Air Inlet Design technology that greatly reduces noise.

PATENTED REVOLUTIONARY AIR INLET DESIGN

The complex issue of noise has created much debate over the years. That is why Biddle have worked closely with Sound Research Laboratories Ltd. (SRL) to gain a better understanding of how fan coil noise can be reduced, and also to develop with HEVAC what is hoped will become an industry standard methodology for calculating NR levels. The air intake end of the traditional fan coil has been dramatically re-engineered and the resulting design patented.

The traditional single inlet has been replaced by two smaller side inlets, with:

- Noise being reflected back within the unit
- Noise splitting equally between the two side inlets and halved
- C.4dB less noise from the inlet end when compared with the noise from a fan coil with the traditional single inlet end
- Anyone situated beneath the return air grille hearing only half the direct noise of that from a unit with the traditional single inlet

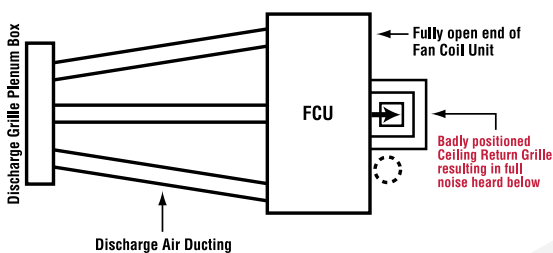

Traditional fan coil - plan view

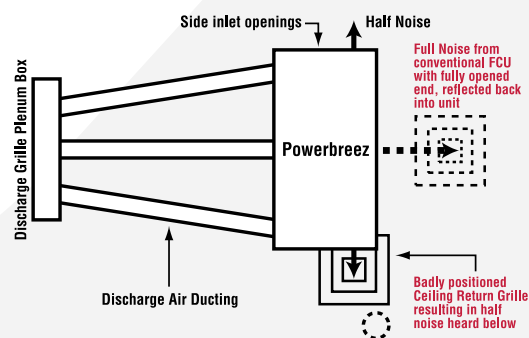

Powerbreez - plan view

HOW IT WORKS

INCREASED OUTPUT

Positioning the fans in a draw-through arrangement (ie. the fans on the discharge air side of the heating / cooling coil) reduces inlet noise, distributes air more evenly over the coil and results in 5% greater output. In addition by utilising a purpose designed non-handed counter flow coil (as opposed to the traditional cross flow coil), fitted upright within the unit, we ensure better heat transfer and a further increase in output of c.20%. This is particularly useful with high cooling water flow temperatures and makes Powerbreez the only viable fan coil for use as a delivery system with sustainable low energy ground source heat pumps.

Using an anti-vibration mounting system to isolate the new design fan deck from the rest of the unit has significantly reduced resonance and casing breakout noise. Features such as fixing brackets to locate the fans on the fan plate, special low hum motors with ventilation slots and high temperature lubricant have enhanced performance and reliability levels to that usually associated with external rotor motor fans.

Critically, each of the inlets contains a number of air vanes which, as well as aiding the reflection of noise back into the unit, guide the direction of the air and ensure an even distribution across the heating/cooling coil.

SITE ADJUSTABLE FAN SPEEDS

Each size in the range has a 36 speed transformer, from which we select nine fan speeds (three 'main' fan speeds each with three 'fine adjustment' settings). When on site it is simple to use the two rocker switches mounted on the side of the controls box to adjust the fan speed to the one that best suits the particular application.

COMPLIANT WITH BUILDING REGULATIONS

Part L2 of the new regulations specifically states that fan coils must not have a specific fan power (a measure of a fan's energy efficiency, being the amount of energy consumed in moving each litre per second of air) exceeding 0.8 W/ls-1, when measured as the rating weighted average of the fan coil unit installation. Although typical fan coils use 2 pole AC fan motors with a specific fan power of 0.9 W/ls-1 or higher, Powerbreez has always used more efficient 4 pole AC fan motors with a specific fan power of between 0.5 W/ls-1 and 0.7 W/ls-1.

EASE OF COMMISSIONING

Consideration of coil margin performance effect, as per BSRIA Guide to 'Commissioning Water Systems', when designing the unit has resulted in a wider site tolerance than is usually allowed when setting water flow rates. And the 'fine adjustment' rocker switch on the side of the controls box enables precise setting of fan speed without any need to change the internal wiring to the transformer.

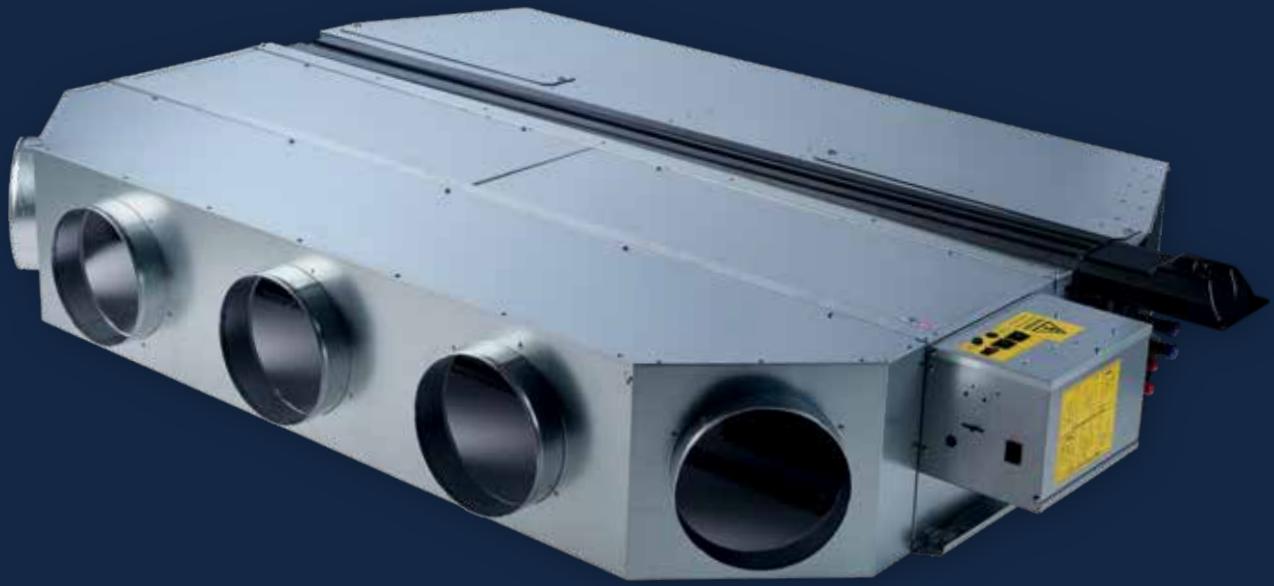

MAINTENANCE AND CLEANING

Access to both the fans and filters is designed to simplify cleaning and maintenance. Split access panels on the larger units enable a single person to handle the panel and access the fans without any need to dismantle the ceiling grid. Cardboard frame EU3 grade panel filters extend the period of time between filter changes, but when they do need replacing each individual filter can be withdrawn either from the side or bottom of the unit via captive 1/4 turn fasteners, and without using tools or disturbing the ceiling grid.

Condensate is removed by use of a 4mm thick 'w' shaped flame-retardant ABS plastic drain tray, with a positive fall to a 15mm outlet. Use of high quality plastic eliminates any possibility of corrosion and makes high temperature steam cleaning practical. If necessary the tray can easily be removed on site.

CONTROLS

The ventilated controls box is designed to accommodate all the commonly used fan coil controllers, any associated electrical components and the transformer. The controls box is mounted on the same side of the unit as the valves and actuators, but if space is particularly restricted the box can be sited on the opposite side or even remote to the unit. To assist access two sides of the box are hinged, allowing the box to be opened up fully. Mounted on the outside of the box are the label detailing pipework connections, a neon on/off switch, the fan speed selection switches, a 3.15amp fuse and a 2.0amp fuse holder (this fuse is fitted if a 24volt controller is used).

SPECIFICATIONS

CHASSIS

Manufactured in the main from 16gauge (1.6mm thick) galvanised steel which is folded, welded and riveted together to form a rigid and solid structure with a smooth finish. However to ease handling on site, access panels are manufactured from lighter 20gauge (1.0mm thick) galvanised steel. Slotted fixing holes, strengthened with additional 16gauge (1.6mm thick) galvanised steel on sizes PB3 to PB6, are provided in the top of the unit to accept M10 drop rods or fixing bolts. The air intake end of the chassis incorporates the Patented Revolutionary Air Inlet Design.

PATENTED REVOLUTIONARY AIR INLET DESIGN

Manufactured from 20gauge (1.0mm thick) galvanised steel, with each of the two specially shaped side inlets containing air vanes to control air flow and minimise noise.

DISCHARGE PLENUMS

Manufactured from 20gauge (1.0mm thick) galvanised steel, mitred and thermally lined with a number of spigots positioned and sized, when used with blanking caps, to suit site ductwork arrangements.

ACCESS

To simplify cleaning and maintenance, access to the fans is via an insulated panel secured with captive 1/4 turn fasteners. On sizes PB3 to PB6 this panel is split into two, making it small enough to allow a single engineer to remove it without dismantling the ceiling grid. Access to the filters is via panels, at the side or bottom of the unit, secured by captive 'quick release' 1/4 turn fasteners.

DRAIN TRAY

Condensate is removed by use of a 4mm thick 'w' shaped flame-retardant ABS plastic drain tray, with a positive fall to a 15mm outlet. Removal of four screws from the panel securing the tray in position allows the tray to be easily withdrawn for cleaning purposes. A stainless steel drain tray, with a 22mm outlet, is available as an option.

FILTERS

Each unit contains a number of small cardboard frame EU3 grade panel filters, fitted to the inlet side of the unit, which can be withdrawn either from the side or bottom of the unit, via panels secured with captive 'quick release' 1/4 turn fasteners, without any need to use tools or disturb the ceiling grid.

INSULATION

The unit chassis and access panels are thermally lined with self-adhesive closed cell expanded cross linked polyolefin self-extinguishing foam insulation. The adhesive is a modified acrylic resin with high temperature tolerance.

COILS

Of a purpose designed non-handed counter flow style, fitted upright within the unit, and comprising a single block of a four row configuration, providing both cooling and heating. Corrugated aluminium fins, wavy edge and spaced at 2.1mm, are expansion bonded to 3/8" copper primary tubes and brazed in turn to copper headers with a 1/8" BSP hexagonal air vent. It is possible to easily remove the coil from the unit, rotate it around its horizontal axis and refit it in the opposite handing. On sizes PB1 and PB2 the cooling section of the coil terminates in 15mm copper tails, whereas they are 22mm on all the other sizes. The heating section of the coil terminates in 15mm copper tails on all sizes. Coils are leak tested to 30 bar.

FAN/MOTOR ASSEMBLY

Isolated from the rest of the unit, using an anti-vibration mounting system to reduce resonance and breakout noise, and mounted on a fan plate, a single low hum motor with ventilation slots and high temperature lubricant drives double inlet, double width forward curved centrifugal fans. The fans themselves comprise galvanised steel impellers housed in galvanised steel scrolls, with sealed for life and maintenance free bearings. The motors are totally enclosed with a built-in self-resetting thermal overload cut-out and are suitable for use with a 230v 1ph 50Hz mains power supply.

FAN SPEED CONTROL

Achieved using a multi-tapped transformer with 18 outputs/36 fan speeds, factory-wired to two rocker switches, and fitted within a ventilated controls box on the side of the unit. The three position 'main' fan speed switch is set to satisfy the design duty, whilst the three position 'fine adjustment' switch is linked to each of the 'main' speeds to facilitate precise commissioning. An additional 24 volt AC (24VA) output for operation of certain controls packages is also provided as standard.

TEMPERATURE CONTROL

Controls comprising a fan coil controller, a return air or room temperature sensor, valves and actuators shall be fitted in accordance with the project specification. The controls can either be supplied and fitted by Biddle, or 'free issued' to Biddle for factory fitting.

CONTROL BOX

Wired in accordance with the latest electrical regulations the controls box is well ventilated, and mounted on the same side of the unit as the valves and actuators. Removal of four screws enables the box to be detached from the unit for remote mounting or fixing to the opposite side of the unit. To ease access two sides of the box are hinged, and secured shut with a single screw. The fan coil controller, any associated electrical components and the transformer are fitted within the box. The wiring diagram is fixed to the inside face of the box so that it can be readily viewed when the box is opened. Mounted on the outside of the box are the label detailing pipework positions, a neon on/off switch, two fan speed selection switches, a 3.15amp mains fuse and a 2.0amp fuse holder. If a 24 volt controller is used then the 2.0amp fuse is easily fitted. The 'kettle' type plug, with 2m flying lead attached, allows easy connection to a fused spur and pushing the plug into the socket on the side of the controls box provides the unit with mains power.

UNIT DIMENSIONS & WEIGHTS

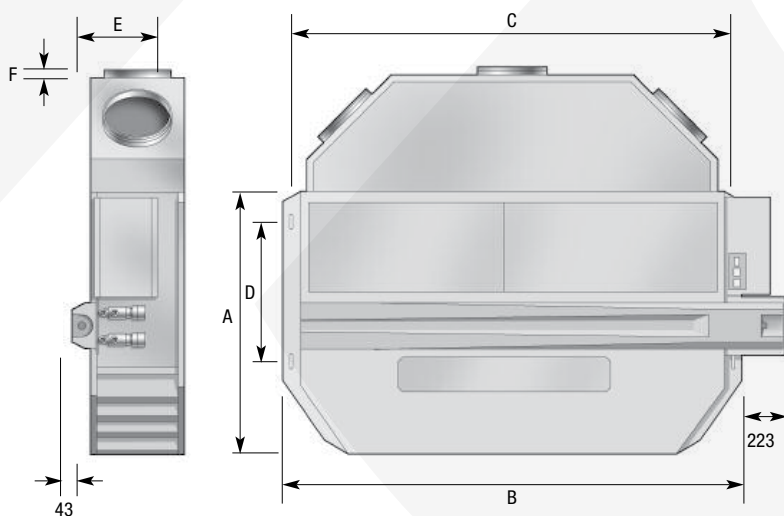

UNIT DIMENSIONS

Unit size	A	B	C	D	E	F
PB5	1050	1595	1557	506	332	57
PB6	1050	1965	1927	506	332	57

Units with electric heating are 125mm longer.

WEIGHTS

Unit size	Unit dry weight* (kg)	Discharge plenum weight (kg)
PB5	105	11
PB6	127	13

* Includes discharge plenum, controls box at 4kg & 2 off valves/actuators at 0.6kg each.

DISCHARGE PLENUMS

DISCHARGE PLENUM

Unit size	Standard spigot sizes (mm)
PB5	4 x 250 \varnothing
PB6	5 x 250 \varnothing

Circular spigots of other sizes are available on request.

If you wish to use a different number and size of discharge spigots, be careful that the discharge duct velocity does not exceed 5m/s.

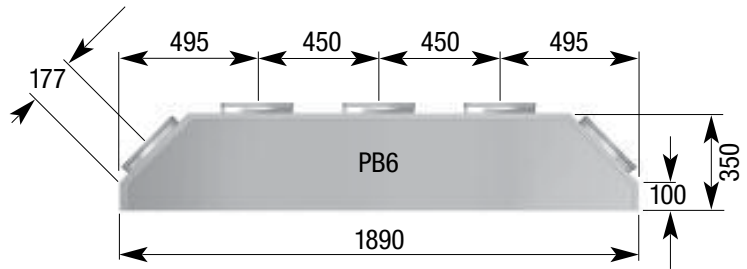
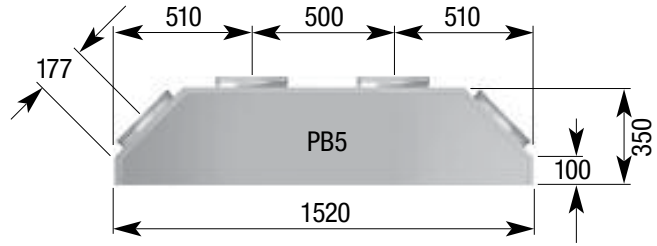

RECOMMENDED 4-PORT VALVE SIZES

Unit size	Cooling	Heating
PB5	2.5kvs, 22mm up to 8kW*	1.6kvs, 15mm
PB6	2.5kvs, 22mm up to 9kW‡	1.6kvs, 15mm

* If over 8kW cooling use 4.0kvs, 22mm.

‡ If over 9kW cooling use 4.0kvs, 22mm.

PIPEWORK POSITIONS

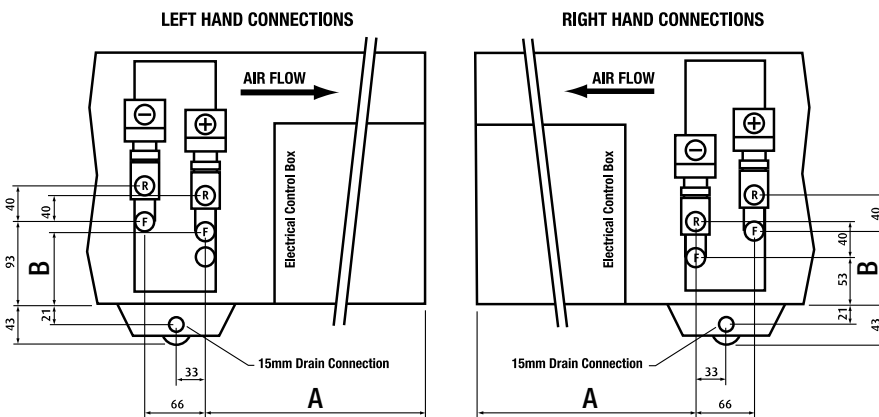

Unit size	A	B
PB5 & PB6	456	133

OPTIONS AVAILABLE

MODEL REFERENCE - Consists of a code giving unit size, coil and casing arrangement.

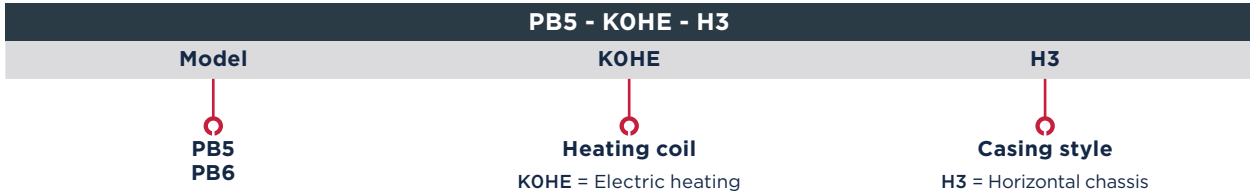

PERFORMANCE DATA

The cooling duties detailed on the following three pages are the maximum achievable based on chilled water temperatures of 6°C flow and 12°C return, and an entering air condition of 23°C/50%rh. They take into account heat 'pick-up' from the fan motor.

The heating duties are the maximum achievable based on hot water temperatures of 82°C flow and 71°C return, and an entering air temperature of 21°C.

For alternative water temperatures and entering air conditions/temperatures, the corrected cooling and heating duties can be calculated by multiplying the duties in the tables by the relevant correction factor.

CORRECTION FACTORS

Entering air temperature (°C)	Chilled water flow & return temperatures (°C)		
	5/11	6/12	7/13
21	0.92	0.84	0.76
22	1.00	0.92	0.84
23	1.08	1.00	0.92
24	1.16	1.08	1.00

Entering air temperature (°C)	Hot water flow & return temperatures (°C)		
	60/50	82/71	90/70
19	0.62	1.04	1.05
20	0.60	1.02	1.04
21	0.58	1.00	1.02
22	0.56	0.98	1.00

Please bear in mind that these correction factors are only approximate, and the corrected cooling and heating duties should be verified by Biddle's in-house fan coil selection programme.

PERFORMANCE DATA

POWERBREEZ PB5

'Main' fan speed	NR guide (30Pa)	External resistance 30Pa				External resistance 50Pa			
		Airflow (l/s)	Sensible cooling (kW)	Total cooling (kW)	Heating* (kW)	Airflow (l/s)	Sensible cooling (kW)	Total cooling (kW)	Heating (kW)
1(low)110v	29	95	1.63	2.30	2.51	-	-	-	-
120v	30	135	2.21	3.02	3.11	-	-	-	-
130v	31	181	2.77	3.73	3.70	134	2.15	2.99	3.11
140v	32	227	3.38	4.43	4.19	177	2.71	3.65	3.70
150v	33	265	3.88	5.02	4.61	221	3.30	4.33	4.22
160v	34	312	4.52	5.84	5.13	271	3.93	5.08	4.73
170v	36	357	5.13	6.63	5.52	315	4.53	5.86	5.11
180v	37	400	5.72	7.39	5.80	354	5.06	6.47	5.50
190v	38	439	6.26	8.09	6.19	395	5.64	7.30	5.79
200v	39	478	6.90	8.80	6.41	434	6.19	7.91	6.11
210v	40	516	7.36	9.39	6.70	473	6.74	8.61	6.43
12(high)230v	41	586	8.30	10.59	7.22	543	7.69	9.81	6.92

POWERBREEZ PB6

'Main' fan speed	NR guide (30Pa)	External resistance 30Pa				External resistance 50Pa			
		Airflow (l/s)	Sensible cooling (kW)	Total cooling (kW)	Heating* (kW)	Airflow (l/s)	Sensible cooling (kW)	Total cooling (kW)	Heating (kW)
1(low)110v	29	145	2.40	3.33	3.46	93	1.62	2.33	2.68
120v	30	201	3.09	4.17	4.28	148	2.41	3.36	3.57
130v	31	258	3.82	5.02	4.97	198	3.04	4.11	4.24
140v	32	314	4.60	5.95	5.46	249	3.71	4.87	4.85
150v	33	367	5.37	6.94	6.05	303	4.40	5.78	5.35
160v	35	423	6.47	8.36	6.58	352	5.11	6.62	5.86
170v	36	478	7.04	9.09	6.97	405	5.88	7.61	6.37
180v	37	527	7.68	9.93	7.36	452	6.58	8.52	6.76
190v	38	575	8.40	10.85	7.74	500	7.30	9.44	7.14
200v	39	622	9.02	11.66	8.05	549	8.02	10.38	7.58
210v	40	665	9.61	12.42	8.33	600	8.69	11.24	7.96
12(high)230v	42	750	10.75	13.71	8.97	685	9.85	12.74	8.47

ELECTRICAL DATA

Unit size	Fan motor running current*(A)	Fan motor running power*(W)	Full load current (A)	Starting current (A)
PB5	1.09	187	1.40	1.56
PB6	1.42	228	1.84	2.06

*Based upon an external resistance of 30Pa and an operating voltage resulting in a noise level of NR35. Data relating to other external resistances and specific operating voltages is available on request.

OCTAVE BAND SOUND POWER LEVELS

Unit size	External resistance	NR guide	Discharge (dB re 10 ⁻¹² W)								Combined inlet/casing radiated (dB re 10 ⁻¹² W)							
			63 Hz	125 Hz	250 Hz	500 Hz	1000 Hz	2000 Hz	4000 Hz	8000 Hz	63 Hz	125 Hz	250 Hz	500 Hz	1000 Hz	2000 Hz	4000 Hz	8000 Hz
PB5	30Pa	30	42.3	44.3	43.2	42.8	41.2	37.3	29.8	26.4	42.0	45.8	45.2	43.3	41.2	35.2	26.1	22.9
		36	51.3	52.3	51.0	51.4	48.5	44.2	38.1	30.9	48.9	53.7	52.3	50.0	48.5	43.0	34.4	25.2
		38	53.7	54.5	53.1	53.4	50.7	46.6	41.0	33.7	51.5	55.7	54.3	52.7	50.5	45.1	37.0	27.5
PB6	30Pa	30	44.7	46.3	46.2	44.0	38.3	27.6	22.4	22.3	45.7	48.5	47.0	44.7	39.1	28.6	21.1	20.5
		35	53.4	54.2	53.4	51.1	45.4	36.8	31.8	28.1	52.3	54.1	54.5	49.6	44.5	36.9	28.1	22.9
		38	54.8	56.3	56.4	54.5	49.0	40.7	36.8	33.1	54.7	57.3	57.5	53.8	47.8	40.9	32.9	25.7

Separate 'Discharge' and 'Combined Inlet/Casing Radiated' sound power levels have been measured in the twin room acoustic suite at Sound Research Laboratories (SRL).

The full sound power spectrum, incorporating data for each size and each 'main' fan speed at specific external resistances, is available on request.

HYDRAULIC DATA

Water flow rate can be calculated:

$$\text{Waterflow rate (l/s)} = \frac{\text{Heat emission (kW)}}{\text{Water temperature difference (°C)} \times 4.19}$$

The following charts can be used to determine the coil pressure drops. However, Biddle's in-house fan coil selection programme provides this information.

COOLING COIL WATER PRESSURE DROPS

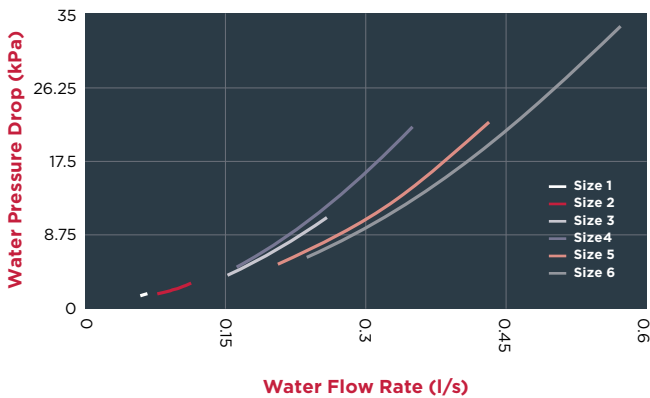

HEATING COIL WATER PRESSURE DROPS

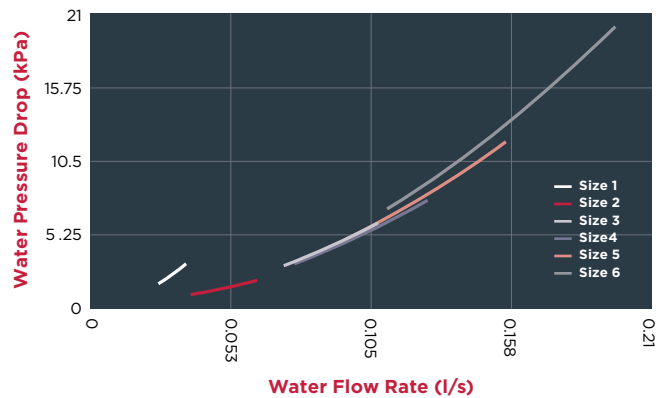

Unit size	Water content of coil (litres)		Coil connection size (mm)	
	Cooling	Heating	Cooling	Heating
PB5	4.3	0.4	22	15
PB6	6.2	0.5	22	15

BIDDLE AIR SYSTEMS

St. Mary's Road
Nuneaton
Warwickshire
CV11 5AU

T +44 (0) 2476 384 233

E sales@biddle-air.co.uk

www.biddle-air.co.uk



Biddle

Every effort has been made to ensure descriptions are correct at the time of print.
Errors and omissions excepted. POWERBREEZ|V1|06|2019