

BAS-XR

Gas Air Heater



Biddle

EFFICIENCY, ENERGY SAVING AND TOTAL COMFORT CONTROL THROUGH UNIQUE DESIGN CHARACTERISTICS

An indirect fired unit air heater with an innovative burner and heat exchanger combination, and of course provided with the latest control technology.

HEAT ON THE RIGHT SPOT

One of the unique characteristics of the BAS-XR is that the heater can be suspended in many positions, either horizontal, vertical or at any angle in between. Therefore easily directing the airflow in the direction required. When discharging vertically, the heater also functions as a destratification fan.

FEATURES AND BENEFITS:

- Very compact
- Reduced weight
- Variable air distribution
- Modulating premix burner and fan
- SS-heat exchanger as standard
- Energy saving
- Simple to install
- Modern design

APPLICATIONS

The compact measurements and the high level of comfort make the BAS-XR suitable for many applications and environments such as showrooms, retail stores, sports centres and even in restaurants, but also in traditional industrial environments.

HOW IT WORKS?

The burner and the fan are both modulating (down to approx. 60%): the room is brought up to temperature at full load and consequently kept at the desired temperature on partial load. This in turn reduces both the energy consumption and the noise level whilst providing the most comfortable working conditions.

Both BAS-XR-models (10-30 and 40-60) have 2 suspension possibilities:

- Bracket for horizontal or vertical air distribution: consisting of 3 U-sections, 2 of which are mounted to the heater and 1 to the wall or to the ceiling. Also available are extension pieces of 1 m. and clamps for mounting the bracket to a steel "H"-section.
- Design bracket: this bracket can rotate in both the horizontal and vertical direction, consequently, the heater can blow in any desired direction. Suitable for mounting on a wall or ceiling (types BAS-XR 10-30).
- The BAS-XR 40-60 have suspension points in each corner for M10 threaded bar. This allows the heaters to be suspended in the conventional manner.

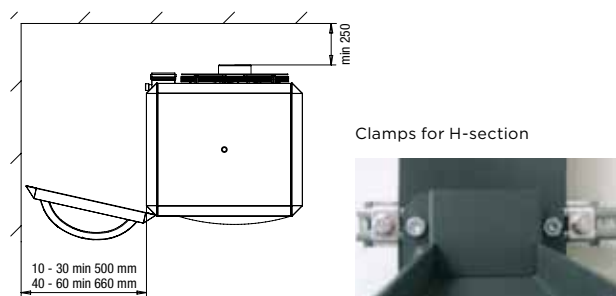

BAS-XR 10-30

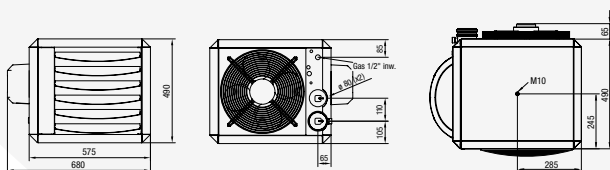

BAS-XR 40-60

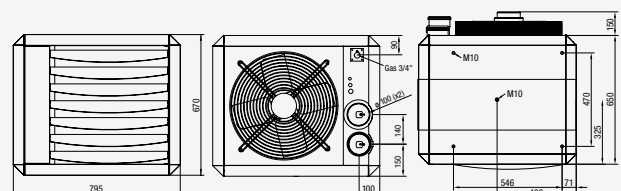

CONTROLS

The BAS-XR series uses an advanced control system which increases the comfort even further. Two temperature sensors, one within the heater and one in the room, measure continuously the temperature gradient. Should the temperature gradient increase beyond the set value, the unit will switch on the fan and circulate the warm air.

The gradient control in combination with the modulating burner and fan can realize energy savings up to 15% in comparison with conventional unit air heaters. Of course the BAS-XR is also provided with a summer ventilation possibility for continuous air circulation.

The controller and thermostats optimize the gradient control by adjusting the modulating gas burner and fan to suit the room conditions. This control strategy provides optimal energy efficiency. For the user, the operation of the thermostat is simple. The user can observe various settings and make any necessary adjustments using the on screen prompts, or detect any recent failures. The Multi Therm is available in 2 models: Standard and Comfort (with various programming possibilities).

Features	MultiTherm S	MultiTherm C
7 day program	○	
10 different on/off programs	○	
Manual override	○	
Summer/Winter time	○	
Modulates the heater according to the room temperature	○	○
Summer ventilation	○	○
Compensation wall influence	○	○
Keyboard locking	○	
Frost protection	○	○
Failure diagnosis and reset per unit air heater	○	○
Wired in twisted pair screened cable	○	○
Controls 1-8 heaters	○	○



Multi Therm S



Multi Therm C

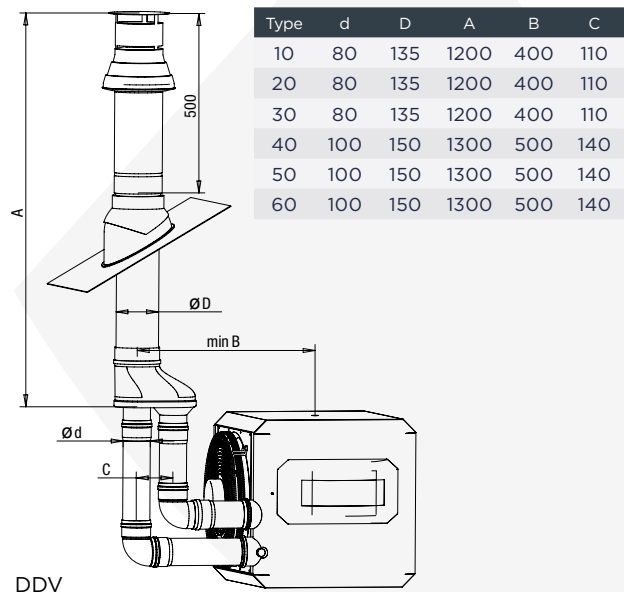
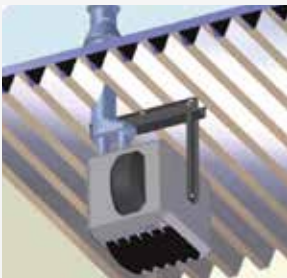

TECHNICAL DATA

Description	Unit	BAS-XR10	BAS-XR20	BAS-XR30	BAS-XR40	BAS-XR50	BAS-XR60
Nominal heat input max.	kW	14.0	22.8	32.0	44.0	55.0	66.0
Nominal heat input min.	kW	9.0	14.8	20.5	26.4	33.0	39.6
Nominal heat output max.	kW	12.8	20.8	29.2	40.2	49.9	60.5
Nominal heat output min.	kW	8.3	13.8	19.1	24.4	30.8	37.0
Air output max.	m ³ /hr	1150	2070	2600	4370	5150	6300
Throw horizontal max.	m	12	16	23	26	28	30
Throw vertical max.	m	5	5	6	7	8	11
Gas connection	G"	1/2 int.	1/2 int.	1/2 int.	3/4 ext.	3/4 ext.	3/4 ext.
Min. Supply pressure G20 (H)	mbar	20	20	20	20	20	20
Max. Gas consumption G20 (H)	m ³ /hr	1.5	2.4	3.4	4.7	5.8	7.0
Gas category		I2H	I2H	I2H	I2H	I2H	I2H
Electrical supply	V	230	230	230	230	230	230
Power consumption max.	W	250	250	250	450	450	600
Noise level*	dB(A)	42	45	45	46	47	49
Minimum suspension height (horizontal air distribution)	m	1.7	1.7	1.7	2.7	2.7	2.7
Minimum suspension height (vertical air distribution)	m	4	4	4	5	6	6
Weight	KG	36	37	38	78	80	82
Dimensions flue terminal	mm	80	80	80	100	100	100

*measured 4m. in front of the heater

BIDDLE AIR SYSTEMS

St. Mary's Road
Nuneaton
Warwickshire
CV11 5AU

T +44 (0) 2476 384 233

E sales@biddle-air.co.uk

www.biddle-air.co.uk



Biddle