

# Manual

# Fan Coil Unit

Model DECO

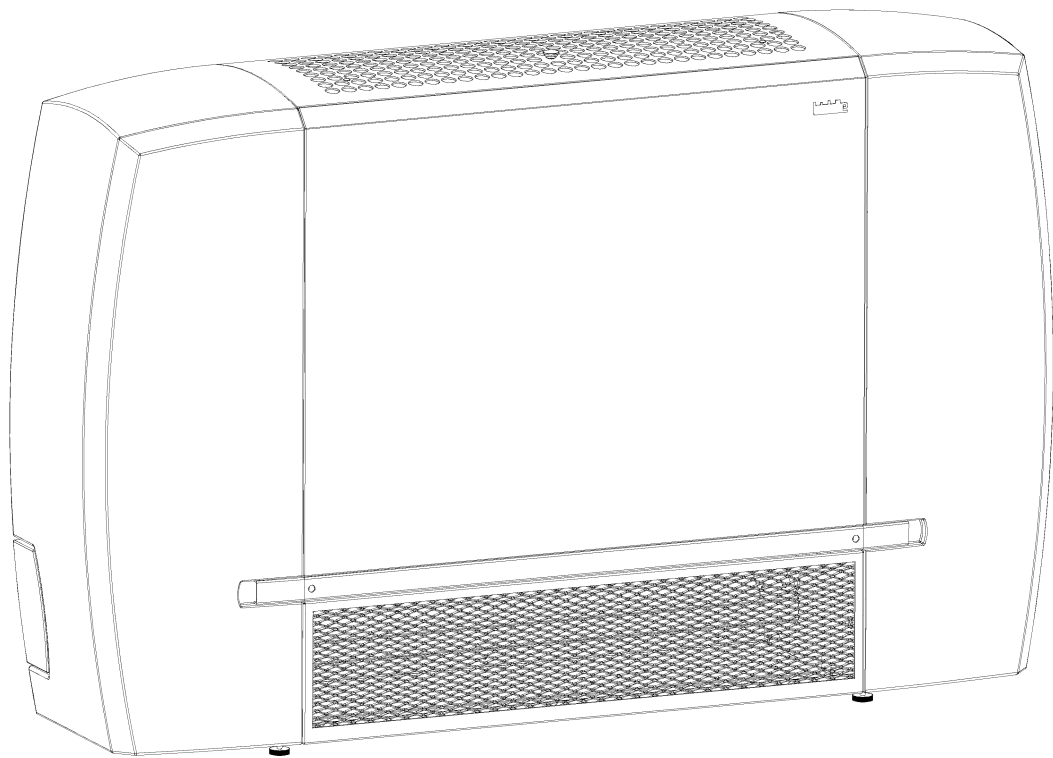

Version of guide: 4.0



**biddle**

## Copyright and trademarks

All the information and drawings in this manual are the property of Biddle and may not be used (other than for the actual operation of the device), photocopied, duplicated, translated and/or be brought to the attention of third parties without Biddle's prior written permission.

The name Biddle is a registered trademark.

## Warranty and Liability

Please refer to Biddle's Terms of Sales and Delivery for warranty and liability conditions.

Biddle excludes liability for consequential loss at all times and under all circumstances.

## Liability for the contents of this manual

However much care might have been taken in ensuring the correctness and, where necessary, completeness of the description of the relevant parts, Biddle disclaims all liability for damage resulting from any inaccuracies and/or deficiencies in this manual.

Should you detect any errors or ambiguities in this manual then we would be pleased to hear from you: it helps us to improve our documentation even further.

Biddle retains the right to change the specifications stated in this manual.

## For more information

If you have any comments or questions about specific topics relating to this product, please do not hesitate to contact Biddle.

Address for the UK:

**Biddle Air Systems Ltd.**

St. Mary's Road  
Nuneaton  
Warwickshire CV11 5AU  
United Kingdom

tel: 024 7638 4233

fax: 024 7637 3621

e-mail: [sales@biddle-air.co.uk](mailto:sales@biddle-air.co.uk)

internet: [www.biddle-air.com](http://www.biddle-air.com)

Address for other countries:

**Biddle bv**

P.O. Box 15  
NL-9288 ZG Kootstertille  
The Netherlands

tel: +31 512 33 55 55

fax: +31 512 33 55 54

e-mail: [export@biddle.nl](mailto:export@biddle.nl)

internet: [www.biddle.info](http://www.biddle.info)

# . . . Table of contents

<b>I</b>	<b>Introduction</b>	<b>5</b>
1.1	About this manual	5
1.2	How to use this manual	5
1.2.1	Marginal symbols	5
1.2.2	Pictograms on the device and in the guide	6
1.2.3	Related documentation	6
1.3	About the unit	7
1.3.1	Uses	7
1.3.2	Working	7
1.3.3	Available models, and type references	7
1.3.4	Type plate	9
1.3.5	Available components and accessories	9
1.4	Safety instructions	9
1.4.1	Operation	9
1.4.2	Installation, maintenance and service	10
<b>2</b>	<b>Installation</b>	<b>11</b>
2.1	Safety instructions	11
2.2	Delivery check	11
2.3	General working method	11
2.4	Mounting wall duct (accessory)	12
2.4.1	Details	12
2.4.2	Mounting	13
2.5	Mounting roof duct (accessory)	13
2.5.1	Details	13
2.5.2	Mounting	14
2.6	Mounting attenuated inlet section (accessory)	15
2.6.1	Details	15
2.6.2	Mounting	16
2.7	Removing side panels from unit	16
2.8	Mounting unit	16
2.8.1	Determining mounting position and method	16
2.8.2	General	18
2.8.3	Mounting wall model	19
2.8.4	Mounting wall model to attenuated inlet section	19
2.8.5	Mounting ceiling model	20
2.9	Connecting unit (models with water heating and/or cooling)	21
2.9.1	Details	21
2.9.2	Frost protection	21
2.9.3	Connecting water pipes	22
2.9.4	Connecting condensate drain	22
2.9.5	Electrical connection	23
2.10	Connecting unit (electrically heated models)	23
2.11	Installing controller	23
2.12	Replacing side panels onto unit	24
2.13	Mounting duct sections and grilles (accessories)	24

2.14	Switching on and checking operation	24
<b>3</b>	<b>Operation</b>	<b>26</b>
3.1	Introduction	26
3.2	Regulating discharge direction	26
<b>4</b>	<b>Maintenance</b>	<b>27</b>
4.1	Replacing or cleaning the filter	27
4.1.1	Introduction	27
4.1.2	Replacing filter	27
4.2	Cleaning the unit	28
4.2.1	Exterior	28
4.2.2	Inlet grille	28
4.2.3	Discharge grille	28
4.3	Periodical maintenance	29
<b>5</b>	<b>Service</b>	<b>31</b>
5.1	Safety instructions	31
5.2	Opening unit	31
5.2.1	Removing side panels	31
5.2.2	Removing front panel	31
5.2.3	Opening the electronics compartment	32
5.3	Replacing fuses	32
	<b>EC declaration of agreement</b>	<b>36</b>

# 1 . . Introduction

## 1.1 About this manual

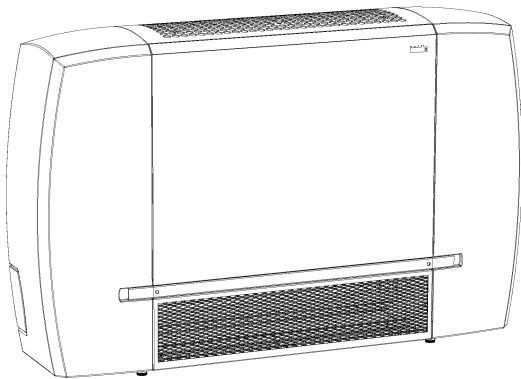

This manual describes the installation, operation and maintenance of the fan coil unit, model DECO. It also describes repair operations.

This manual only relates to the unit itself. A separate manual covers the operation and control of the unit.

## 1.2 How to use this manual

### 1.2.1 Marginal symbols

In this guide the following marginal symbols are used:



**Note:**

Draws your attention to an important part of the text. Read this part of the text carefully.



**Caution:**

If you do not perform this procedure or action correctly you can damage the device.

So follow the instructions carefully.



**Warning:**

If you do not perform this procedure or action correctly you can cause bodily injury and/or damage.

So follow the instructions carefully.





**Danger:**

**This indicates actions which are not permitted. Ignoring this warning can lead to serious damage or accidents which may involve bodily injury. The action concerned may only be performed by qualified technical staff when carrying out maintenance or repair.**

**1.2.2 Pictograms on the device and in the guide**

The pictograms in Table I-I refer to possible risks and/or dangers. You will find these pictograms in the text when risky actions are being discussed. The same pictograms will also be found on the device.

**Table I-I** Pictograms

PICTOGRAM	DESCRIPTION
	<p><b>Warning:</b> You are entering an area which contains 'live' components. Accessible to qualified maintenance staff only. Caution is urged.</p>
	<p><b>Warning:</b> This surface or part can be hot. There is a risk of burns on contact.</p>

**1.2.3 Related documentation**

Besides this manual, the following documents come with this unit:

- documentation for control and operation,
- wiring diagram for the installer.

## 1.3 About the unit

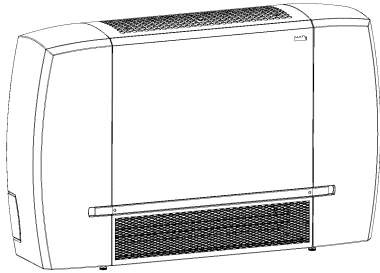

### 1.3.1 Uses

The fan coil unit is designed for heating, cooling and/or ventilating rooms. The unit is positioned in the room in such a way that the discharged air flow is distributed evenly across the room without causing discomfort to the people in it.

In general illustrations in this manual, the following unit type is used as a sample: DECO 50-H2-L-FS10. The appearance of your unit may be different but its working is identical, unless stated otherwise.

### 1.3.2 Working

The fan coil unit blows a flow of hot or cold air into the room at an adjustable angle. The integral control automatically determines the required volume and correct temperature of the air. The air may be taken in either from outside (ventilation) or from the room itself (re-circulation). Thus, the unit offers two benefits:

- The room is kept at the desired temperature.
- Gradual deterioration of air quality in the room is counteracted.



### 1.3.3 Available models, and type references

Table 1-2 on page 8 provides an overview of available fan coil unit models, and corresponding type references. Combined, the type references constitute the type code, for instance: DECO 50-H2-R-FS10-M. Several combinations may appear.

**Table 1-2** Type code explained

<b>TYPE CODE ELEMENT</b>	<b>REFERENCE</b>	<b>MEANING</b>
model range	DECO	fan coil unit (general)
unit size	50, 75, 100, 125 or 150	different unit sizes
heating or cooling coil	H1, H2 or H4	water-heated, 1-, 2- or 4-row
	C2, C3 or C4	water-cooled, 2-, 3- or 4-row
	H1C3	water-heated and -cooled, 1- or 3-row
connection side	L	water connections to the left, electric connections to the right
	R	water connections to the right, electric connections to the left
mounting method	F	wall model
	C	ceiling model
appearance	S	cased model 'Stylish' (round side panels)
	B	cased model 'Business' (straight side panels)
	R	chassis model (without casing)
main functions, and hole positions	2	with re-circulation, hole in front (with ceiling models, in bottom)
	4	with re-circulation, hole in bottom (with ceiling models, in back)
	6	with ventilation, hole in back (with ceiling models, in top)
	8	with ventilation, hole in bottom (with ceiling models, in back)
	10	with re-circulation and ventilation, holes in front and back (with ceiling models, in bottom and top)
	12	with re-circulation and ventilation, holes in front and bottom (with ceiling models, in bottom and back)
control	M	Modulating control
	S	Speed control
	I	<i>Interface</i> , either with or without touch pad control
	B	<i>Basic</i> , without controller (optionally with controller)
	<i>no reference</i>	<i>not described in this manual</i>



 Biddle bv Markowei 4 NL-9288 HA Kootsterlille  	Type	DECO 50-H2-R-FS10-BASIS		
	Code		U	230 V 1N- 50 Hz
	N°	205020/1-1 00-01	I <sub>max</sub> L1	0.44 A
			I <sub>max</sub> L2	-
	M	36 kg	I <sub>max</sub> L3	-
	Medium	LPHW	P <sub>motor</sub>	0.10 kW
		P <sub>max</sub> 1400 kPa	P <sub>heating</sub>	-

### I.3.4 Type plate

The type plate is located above the electrical connections on the inside of the back panel.

The following data on the type plate are referred to in this manual:

- ‘Type’ represents the full *type code* of the unit,
- ‘M’ represents the weight of the unit.

### I.3.5 Available components and accessories

#### Components

Depending on the model and type, control components will be required, such as a control panel, control cables, etc. (see the documentation of the controller)

#### Accessories and options

The following accessories are available:

- wall duct;
- wall grate;
- roof cap;
- flexible connection sleeves, with or without connecting flange;
- wall and ceiling grilles for recessed models, fixed or adjustable;
- discharge section for chassis models;
- attenuated inlet section;
- condensate discharge pump (mounted in unit, standard in encased ceiling models with cooling).

## I.4 Safety instructions

### I.4.1 Operation



#### **Warning:**

**Do not put any objects in the inlet and discharge openings.**



#### **Warning:**

**Do not block the air inlet and discharge openings.**



**Warning:**  
The top of the unit may get hot.

#### 1.4.2 Installation, maintenance and service



**Danger:**  
The unit may be opened by qualified technical staff only.



**Warning:**  
Perform the following actions before opening the unit:

1. Switch the unit OFF.
2. Wait until the fans have stopped. Allow the unit to cool down.



The heating can get very hot. Also, the fans may keep on rotating for some while.

3. Disconnect power supply (remove plug from socket or move main switch to OFF).
4. Close CH supply (if possible).



**Warning:**  
The fins of the heat exchanger may be sharp.

# 2 . . Installation

## 2.1 Safety instructions



**Danger:**  
Installation works on the unit may be performed by qualified technical staff only.



**Warning:**  
Before opening the unit, follow the safety instructions in section 1.4.

## 2.2 Delivery check

- Check the unit and its packaging for correct delivery. Immediately report to the supplier any damage caused in transit.
- Check whether all parts are included.

## 2.3 General working method

- Biddle recommends following the order of working described in this chapter for performing the installation works.
- Some parts of this section are applicable only to certain models of the fan coil unit. Where this is the case, it will be indicated so. If no specific model is referred to, the description will apply to all models.



**Note:**  
Make sure you perform all installation operations that are required for your unit.

Check the type plate. Refer to section 1.3.3 'Available models, and type references' if you are not sure about the model or type of your unit.



**Caution:**

Taking in building dust, grit, cement powder etc. may damage the unit. While such substances are present in the room:

- do **not** start to use the device,
- cover air intake and discharge openings.

You may cover the unit with the packaging material.

**Cased models**



**Caution:**

Do **not** lift the unit at the side panels.

**2.4 Mounting wall duct (accessory)**

**2.4.1 Details**

The wall duct is made up of two parts which, when slid into one another, are suitable for various wall thicknesses.

**Table 2-1** Wall duct dimensions

	<p><b>DECO 50</b></p>	<p><b>DECO 75</b></p>	<p><b>DECO 100</b></p>	<p><b>DECO 125</b></p>	<p><b>DECO 150</b></p>
<p>size A (width of hole)</p>	<p>503</p>	<p>753</p>	<p>1003</p>	<p>1253</p>	<p>1503</p>
<p>size B (distance from unit base to hole)</p>	<p>17.5 – 32.5 (The unit's standing height is adjustable.)</p>				
<p>size C (wall thickness)</p>	<p>205 – 355 or 350 – 650 (depending on model)</p>				
<ul style="list-style-type: none"> <li>• All dimensions are in mm.</li> <li>• Size B relates only to standing wall models.</li> </ul>					

### 2.4.2 Mounting



#### **Caution:**

Mount the wall duct carefully, and provide for proper sealing. Otherwise draught and condensation problems may occur, affecting the operation of the fan coil unit.

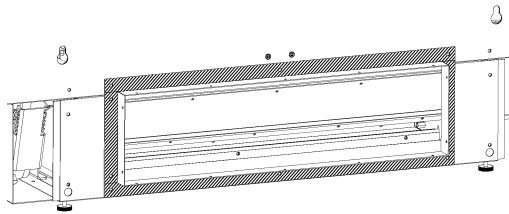

1. Apply expanding foam gasket (included) around the unit's ventilation opening (the shaded area in the figure).
2. Make an opening through the wall (see Table 2-1 for dimensions).
3. Fix the duct sections as you please, e.g., by bricking them in or by fixing them with screws. In doing so, note the positions of the screws: these must not hinder the installation of the grate.
4. Carefully seal all seams and cracks with a sealant.
5. On the flanges of the duct section that is fixed to the outer wall: drill through the grate holes using a  $\varnothing$  5 mm drill.
6. Apply sealant to the inner side of the grate flanges, properly sealing the gap between grate and duct.
7. Mount the grate to the flanges using sheet metal screws.

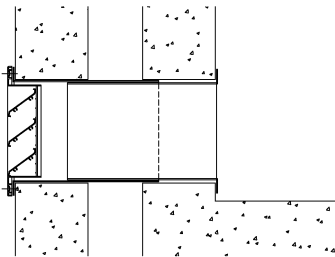

#### **Note:**

In doing so, note the correct position of the blades: these should be oriented outward to allow for run-off.

8. Finish the wall duct in a draught-proof manner.

## 2.5 Mounting roof duct (accessory)

### 2.5.1 Details

The roof duct is made up of two parts: a cap and a pipe. On delivery, the two parts are attached to one another.

The roof duct is mounted to a roof curb. The roof curb is not included in the delivery, and is to be made on site.

**Table 2-2** Roof duct dimensions

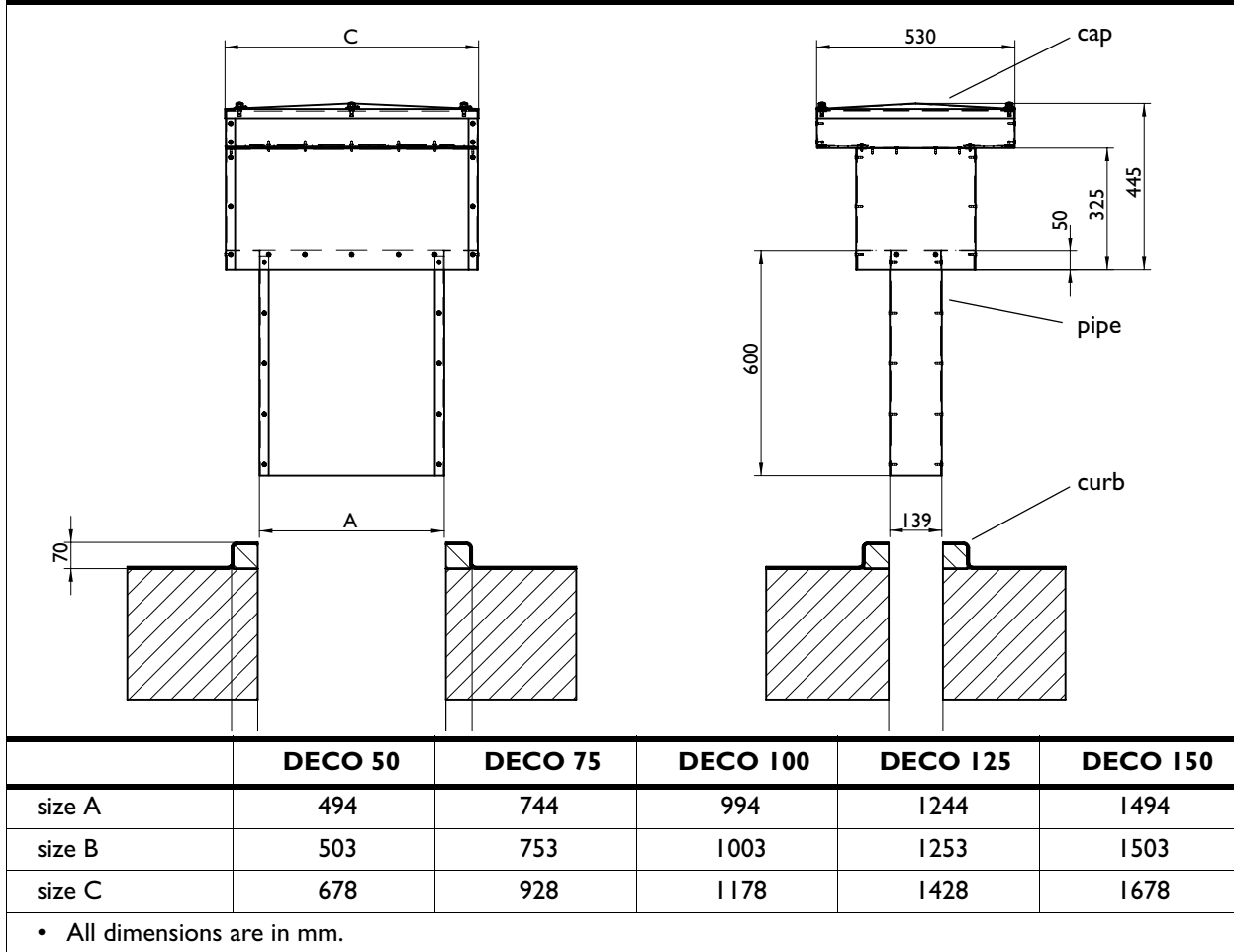

**2.5.2 Mounting**



**Caution:**

Mount the roof duct carefully, and provide for proper sealing. Otherwise draught and condensation problems may occur, affecting the operation of the fan coil unit.

1. Apply expanding foam gasket (included) around the unit's ventilation opening (the shaded area in the figure).
2. Make an opening through the roof (see Table 2-2 for dimensions).

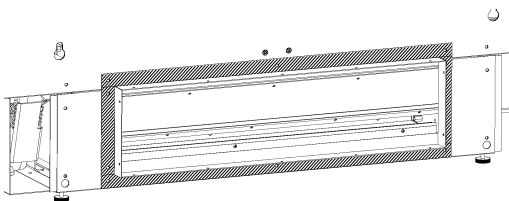

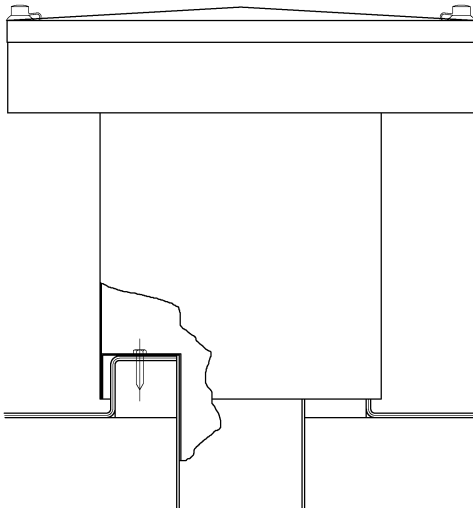

3. Make the curb around the opening. Apply roofing felt or bitumen onto the curb, making it watertight.
4. Remove the cap from the pipe. To do so, loosen the screws in the upper side of the cap.
5. Slide the pipe into the roof opening, and fix it to the curb.
6. Mount the cap to the pipe.
7. Seal all cracks that have arisen during installation, making the unit draught- and leakage-proof.

## 2.6 Mounting attenuated inlet section (accessory)

### 2.6.1 Details

The attenuated inlet section will be fixed to the wall. Next, the unit will be fixed to the inlet section.

**Table 2-3** Wall duct dimensions for inlet section

<p>A technical cross-section diagram of the inlet section. It shows a rectangular unit mounted on a wall. The unit has a circular inlet on the left side. The diagram includes two dimension lines: one indicating a height of 142 x C and another indicating a depth of 451,5 - 466,5.</p>	<b>DECO 50</b>	<b>DECO 75</b>	<b>DECO 100</b>	<b>DECO 125</b>	<b>DECO 150</b>
<p>size C</p>	503	753	1003	1253	1503
<p>• All dimensions are in mm.</p>					

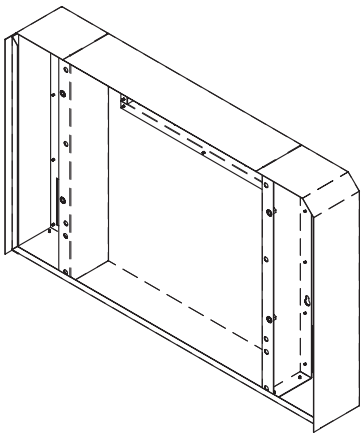

**2.6.2 Mounting**

1. Apply expanding foam gasket (included) around the inlet section's ventilation opening.
2. Make an opening through the wall (see Table 2-3 for dimensions).
3. Fix four M8 bolts into the wall. (The dimensions are identical to those for fixing the unit: see Table 2-4 on page 18.) Make sure the bolts are level.
4. Suspend the inlet section from the bolts using the key-holes in the back.
5. Tighten the bolts.

**2.7 Removing side panels from unit**

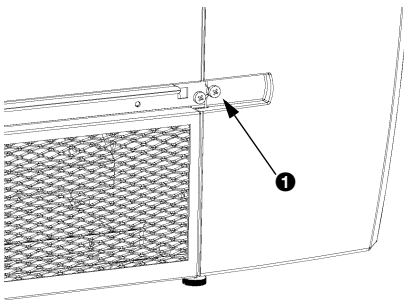

**Cased models only**

To make the unit accessible for mounting it and for connecting water pipes and/or electric wiring, the side panels must be removed.

1. Loosen the quarter-turn fasteners, and remove the filter frame.
2. Behind the frame, each face has a screw **1** that holds the side panel in place. Remove this screw.
3. Lift the panel carefully, and remove it forward.

**2.8 Mounting unit**

**2.8.1 Determining mounting position and method**

**All models**

- Make sure the structure from which the fan coil unit is to be suspended is capable of bearing the unit. The weight is specified on the type plate (see section 1.3.4).
- Ensure the air can flow freely through the unit's inlet and discharge openings.
- Position the unit such that the connections will be easy to access both during and after installation.



### Wall models

- Position the unit on an as level as possible surface for maximum support. Level the unit using the adjusting feet.
- The unit can also be suspended from the wall using the four keyholes in the back.
- If the unit is positioned on the floor, there is no need for securing it, but if you do, use the keyholes in the back.

### Wall models with ventilation

- Provide for proper support. Otherwise, the ventilation valve will not close properly, and draught may occur.
- If fresh air is let in, it is recommended to secure the unit to the wall to ensure the wall duct is properly sealed.

### Wall models with attenuated inlet section

- Position the unit on the floor, securing it to the inlet section.
- You may also suspend the unit from the inlet section without support.

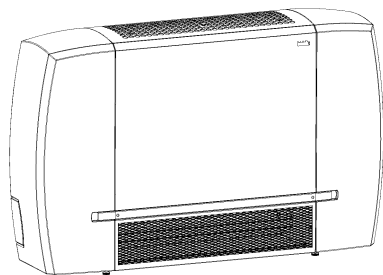
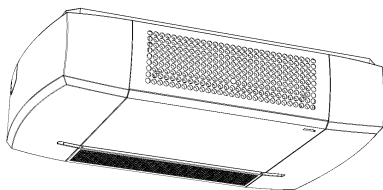
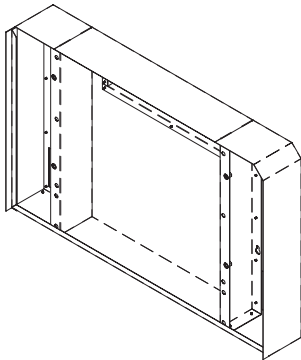

### Ceiling models

- The unit can be suspended from the ceiling using the four keyholes in the back.
- Another option is to suspend the unit from threaded rods.

### Cased models

- After installation, it should still be possible to remove the side and front panels to gain access to the connections.

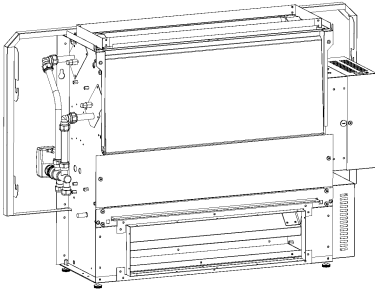

**Chassis models**

- After installation, it should still be possible to remove the casing to gain access to the connections.

**Chassis models with re-circulation (DECO FR4, CR4)**

- Do NOT position the unit such that its bottom is on the floor or against the wall. Ensure the distance to the floor or wall is at least 120 mm.

**2.8.2 General**



**Caution:**  
Level the unit.

Otherwise, air will be left in the coil, or (in units with cooling) condensate will not drain off properly.

**Table 2-4** Unit mounting dimensions

		DECO 50	DECO 75	DECO 100	DECO 125	DECO 150
size A		644	894	1144	1394	1644
size B		288	288	288	288	288
size C	ceiling models	213	213	213	213	213
	wall models	218	218	218	218	218
	chassis re-circulation models (DECO FR4, CR4)	71	71	71	71	71
• All dimensions are in mm.						

### 2.8.3 Mounting wall model

#### Floor positioning

1. Position the unit on the surface, and stabilise and level it using the adjusting feet in the bottom.
2. You may want to secure the unit to the wall. (See below.)

#### Suspending from or securing to wall

1. Apply four M8 bolts. (For dimensions, see Table 2-4.) Ensure the bolts are level.
2. Suspend the unit from the bolts. Perform this with at least two persons. (The unit's weight is specified on the type plate, see section 1.3.4.)
3. Tighten the bolts.
4. Check the suspension for stability:
  - Try to push the unit from the bolts.
  - Shake the unit for a few seconds.

### 2.8.4 Mounting wall model to attenuated inlet section

#### Floor positioning

1. Position the unit against the inlet section at equal heights on the floor. The edge of the inlet section should enclose the back panel of the unit.
2. Stabilise and level the unit using the adjusting feet in the bottom.
3. Secure the unit to the inlet section using 4 M8 bolts, through the keyholes in the back panel.

#### Suspending from inlet section

1. Ensure the unit has the same height as the inlet section by using a temporary prop.



**Note:**

It is not possible to hook the unit onto the inlet section using the keyholes.

2. Place the unit against the inlet section: the edge of the inlet section should enclose the back panel of the unit.

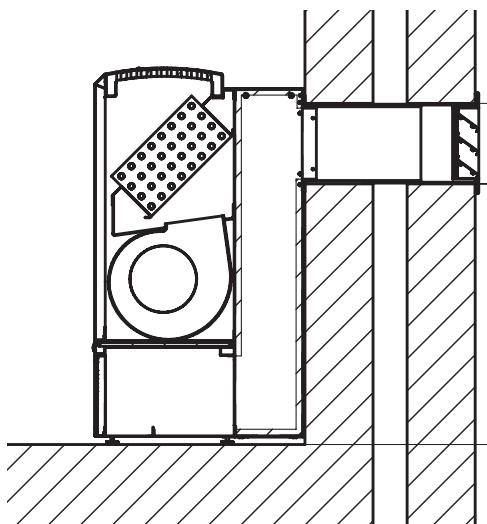

3. Fix the unit to the inlet section using 4 M8 bolts, through the keyholes in the back panel.
4. Remove the temporary prop from underneath the unit.
5. Check the suspension for stability:
  - Try to push the unit from the bolts.
  - Shake the unit for a few seconds.

**2.8.5 Mounting ceiling model**

**Suspending directly from ceiling**

Suspension using screws

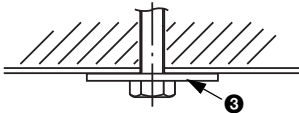

1. Fix four screws or bolts of a maximum diameter of 8 mm. (For dimensions, see Table 2-4.)
2. Suspend the unit. Perform this with at least two persons. (The unit's weight is specified on the type plate, see section 1.3.4.)
3. Use the included locking rings with slotted holes: insert the locking rings ③ between the bolt or screw head and the panel.
4. Tighten the screws or bolts onto the panel.
5. Check the suspension for stability:
  - Try to push the unit from the bolts or screws.
  - Shake the unit for a few seconds.

**Suspending from threaded rods**

Suspension using threaded rods

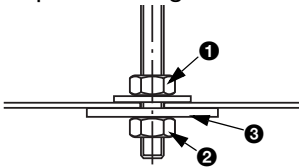

1. Fix four M8 threaded rods. (For dimensions, see Table 2-4.) Make sure the threaded ends are perpendicular.
2. Provide each threaded end with two nuts (① and ②) with a mutual space of some centimetres.
3. Suspend the unit from the lower nuts. Perform this with at least two persons. (The unit's weight is specified on the type plate, see section 1.3.4.)
4. Use the included locking rings with slotted holes: insert the locking rings ③ between the nuts ② and the panel.
5. Tighten the upper nuts ① onto the panel.
6. Check the suspension for stability:
  - Try to push the unit from the nuts.
  - Shake the unit for a few seconds.

## 2.9 Connecting unit (models with water heating and/or cooling)

### 2.9.1 Details

- Depending on the model and type, the connections have female-thread fittings or compression fittings.
- The unit may come with premounted control valves, to which the CH and/or CW system is (are) to be connected.
- The supply and return connections of heat exchangers are indicated with arrows:
  - red arrows: heating
  - blue arrows: cooling
- The (1/8") vent cocks are mounted to the collectors. They can be opened using the included key.
- The maximum operating pressure depends on the water temperature: see Table 2-5.

**Table 2-5** Operating pressure in CH/CW system

TEMPERATURE	OPERATING PRESSURE
20 °C	16 bar
93 °C	10 bar
110 °C	6 bar



**Note:**

Biddle recommends the inclusion of a valve in each pipe.

### Cased models

- Allow for cable and pipe entries.

Connection can be done through the bottom or, after removal of the filling piece, through the side panel opening. With ceiling models, the bottom panel must be removed to enable connection through the bottom.

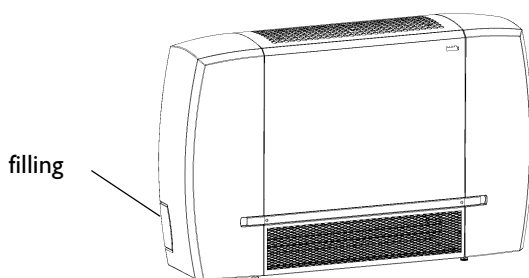

### 2.9.2 Frost protection

#### Models with ventilation only

Depending on the control system, the unit has a frost protection thermostat or a controller-integrated protection.

**Caution:**

The frost protection reduces the risk of freezing but does not warrant 100% protection.

To prevent the heat exchanger from freezing:

- ensure a constant circulation of water at a correct temperature;
- when not in operation during the wintertime, glycol must be added to the water.

**2.9.3 Connecting water pipes**

1. Lay the water pipes, and connect them to the heat exchanger.

**Caution:**

Tighten the compression fittings well.

2. Fill the CH and/or CW system.
3. Vent the heat exchanger.
4. Check the connections for leaks.

**2.9.4 Connecting condensate drain****Models with water cooling only**

The unit comes with a condensate drain tray with a Ø 15 mm drain pipe.

Ceiling models with both casing and cooling come as standard with a condensate discharge pump.

1. Install a sewer connection incl. stink trap for the discharge of condensate.
2. Connect the condensate drain tray to a flexible hose.
3. Connect the hose, with a stink trap, to the sewer.
4. Insulate the pipes that are not hanging over the condensate drain tray.

### 2.9.5 Electrical connection

- Ensure an earthed (grounded) power point is available at no more than 1.5 m from the unit's connection side (depending on model).



**Warning:**  
The unit must be earthed (grounded).

## 2.10 Connecting unit (electrically heated models)

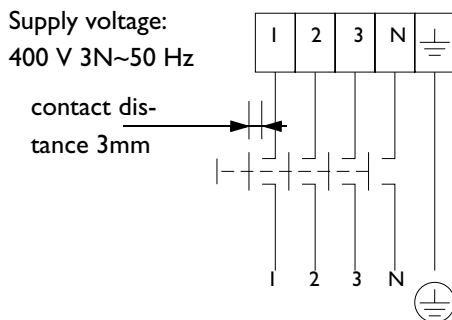

**Warning:**  
Ensure the mains supply group you are working on is switched off.

1. Install an all-pole switch with a minimum contact distance of 3 mm.
2. Connect the switch to the mains.



**Caution:**  
Do not yet apply voltage to the circuit.



**Warning:**  
The unit must be earthed (grounded).

## 2.11 Installing controller

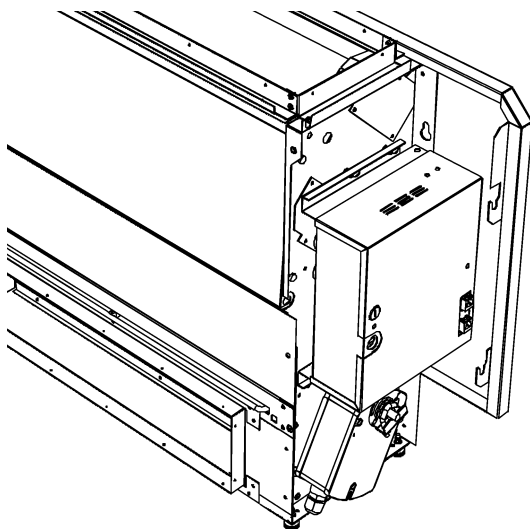

Depending on the type, the unit can be fitted with electronic operation and/or control. Install these according to the respective manuals.

The connections are located on the electronics compartment or on the control unit's PCB in the compartment. (see Section 5.2.3)

## 2.12 Replacing side panels onto unit

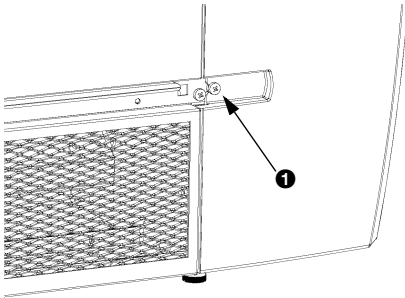

### Cased models only

1. Hook the side panels into the three eyes on the unit's side face.
2. Fix the panel to the front face using screw ❶.
3. Position the filter frame, and fix it with the quarter-turn fasteners.

## 2.13 Mounting duct sections and grilles (accessories)

### Chassis models only

The unit may be provided with flexible connection sleeves or with flanges to which duct sections or grilles can be connected. Mounting these parts depends on the local situation, and is to be carried out according to your own judgment. Follow the below instructions in order not to affect the unit's performance:

- Avoid abrupt duct transitions.
- Keep ducts as short as possible.
- Do not apply any grille that is much smaller than the unit opening.
- Mount flexible connection sleeves to the inlet opening under tension; this is to prevent the connection sleeve from being closed at high fan speeds.

## 2.14 Switching on and checking operation

### All models

1. Check the power supply connection.
2. Check the controller connections (see the corresponding documentation).
3. Switch on the mains supply.
4. Make the controller ready for use according to the appropriate manual.



5. Switch on the unit using the controller. Check whether the unit blows out air.

#### **Models with water heating and/or cooling**

Check if the heat exchanger is connected correctly:

1. Make sure the CH and/or CW system is (are) switched on.
2. Let the unit heat and/or cool using the controller.
3. Feel whether the discharged air flow is getting hot (if heating) or cold (if cooling). This may take a little while.
4. Vent the heat exchanger, if necessary.

#### **Models with cooling and condensate discharge pump**

Check the working of the condensate discharge pump:

1. Pour water into the condensate drain tray. The condensate pump should start working shortly.

#### **Models with ventilation**

1. Check the seal of the fresh air duct: it should be draught-free.

#### **For models with ventilation and recirculation**

2. Let the unit ventilate and recirculate using the controller. Check whether the air valve moves to the right positions.
3. Check whether the air valve closes correctly in both open and closed position.

If the valve does not close correctly, the unit may not be level or properly supported. Correct this.

4. Switch the power off, and check if the valve opening closes automatically.
5. Switch the power on again, and recheck the valve for normal operation.

# 3. . Operation

## 3.1 Introduction

The unit allows you to regulate the direction of the discharged air.

Other control options depend on the control system. For that, refer to the relevant documentation.

## 3.2 Regulating discharge direction

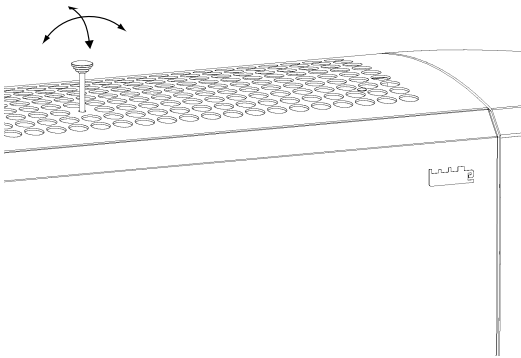

### **Standard in cased models, accessory in chassis models**

The discharge grille has one or more handles to regulate the discharge direction. Pull the handle out, and push it in the desired direction.

Consider the following when setting the direction:

- It is recommended to discharge cold air into a room along a surface (e.g., a wall or ceiling).
- Discharge hot air directly, at a slight angle, into the room.
- Do not direct the air flow to areas where persons are staying for longer periods of time, such as workplaces.

# 4 . . Maintenance

## 4.1 Replacing or cleaning the filter

### 4.1.1 Introduction

The filter must be replaced regularly. A dirty filter may cause inadequate heating, cooling or ventilation as well as a high noise level. The interval at which the filter is to be replaced depends on the local situation.

New filters are available from Biddle. You may also clean the filter material with, for instance, a vacuum cleaner. After some cleanings, however, the filter must be replaced.

### 4.1.2 Replacing filter

#### Cased models

1. Remove the filter frame at the bottom of the unit. To do so, turn two quarter-turn fasteners such that the screw slots are in vertical position.
2. Pull the frame and the filter material gently out of the unit. If you handle the filter too roughly, dust may fall out.
3. Replace or clean the filter.

#### Chassis models

1. Remove (part of) the unit's surrounds.
2. Pull the frame and the filter material gently out of the unit. If you handle the filter too roughly, dust may fall out.
3. Replace or clean the filter.

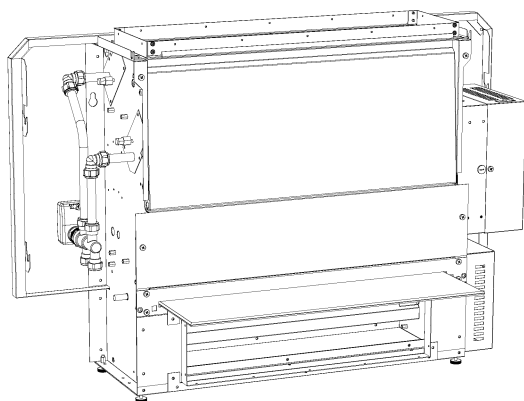
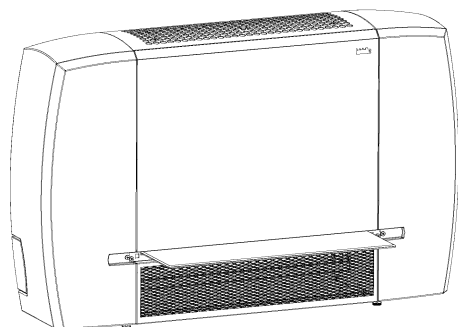

## 4.2 Cleaning the unit

### 4.2.1 Exterior

You may clean the exterior of the unit with a damp cloth and a domestic cleaner. Do not use any solvents.



**Caution:**

Make sure no water runs into the unit.

### 4.2.2 Inlet grille

You may clean the inlet grille of the unit with a damp cloth and a domestic cleaner. Do not use any solvents.

### 4.2.3 Discharge grille

Should coffee or the like fall into the unit, clean the discharge grille.

If the contamination has penetrated deeply into the unit, you should have the unit cleaned by an installer.

### Dismounting the discharge grille

The panels may be cleaned in a dishwasher at low temperature. To do so, the discharge grille must be dismantled.



**Warning:**

Before opening the unit, observe the safety instructions in section 1.4.

1. Remove the filter frame at the bottom of the unit. To do so, turn two quarter-turn fasteners such that the screw slots are in vertical position.
2. Behind the frame, there are two screws ❶ that hold the side panels in place. Remove the screws.
3. Unhook the panel gently, and pull it forward.
4. Dismount the discharge grille by loosening the two screws ❷ on both sides of the grille.
5. Take the grille from the unit, and turn it round.

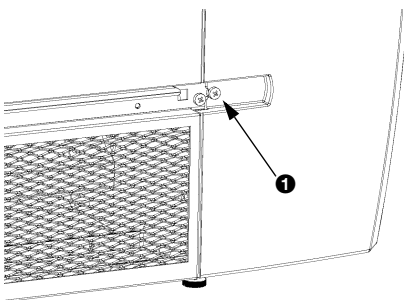

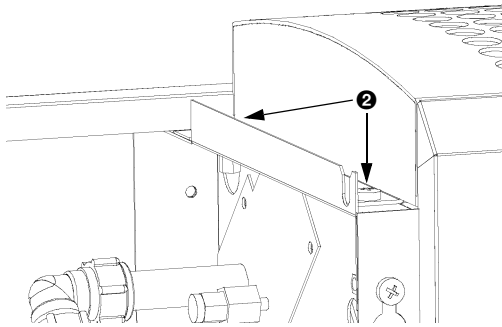

6. Remove the pins and leaf springs, and take the panels out of the grille.
7. Clean the different panels, for instance, in a dishwasher at low temperature.
8. Remount the components in reverse order to dismantling.

### 4.3 Periodical maintenance

Biddle recommends to have the following inspection and maintenance works performed by an installer each year.

#### All models

- Check if the filter is clean enough, and not damaged. Replace the filter if necessary (see section 4.1).
- Check the discharge grille for contamination, and clean it if necessary (see section 4.2.3).
- Check if the heat exchanger or the electric heating coils are clean. Settled dust may cause unpleasant smells.

Gently remove dust with a vacuum cleaner.



#### **Caution:**

The fins of the heat exchanger are delicate parts. Do not damage them.

- Check the operation of the fans.

#### Models with ventilation

- Check if the ventilation valve closes properly in both positions.
- Check if the valve automatically falls to shut if the power supply is interrupted.

#### All models with cooling

- Check if the condensate drain tray and pipe are clean. Contamination may lead to poor drainage and to growth of bacteria and fungi.

**Wall models with cooling**

- Inspect the filter of the condensate discharge pump (accessory) in the float module.

**Ceiling models with cooling**

- Check if the condensate discharge pump (accessory) can take in freely.

# 5 . . Service

## 5.1 Safety instructions



**Danger:**  
Service on the unit may be performed by qualified technical staff only.



**Warning:**  
Before opening the unit, follow the safety instructions in section 1.4.

## 5.2 Opening unit

### 5.2.1 Removing side panels

#### Cased models only

1. Loosen the quarter-turn fasteners, and remove the filter frame.
2. Behind the frame, each face has a screw ❶ that holds the side panel in place. Remove this screw.
3. Lift the panel carefully, and remove it forward.

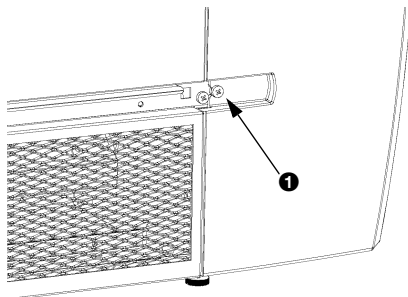

### 5.2.2 Removing front panel

#### Cased models

1. Remove the side panels. (see section 5.2.1)
2. Each side of the front panel has two screws ❶: loosen them.
3. Remove the front panel.

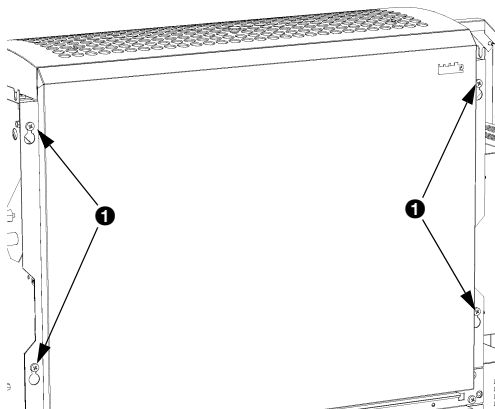

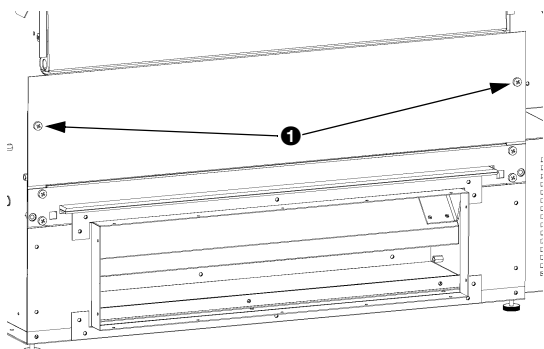
**Chassis models**

1. Remove the surrounds.
2. Each side of the front panel has one screw **1**: loosen them.
3. Remove the front panel.

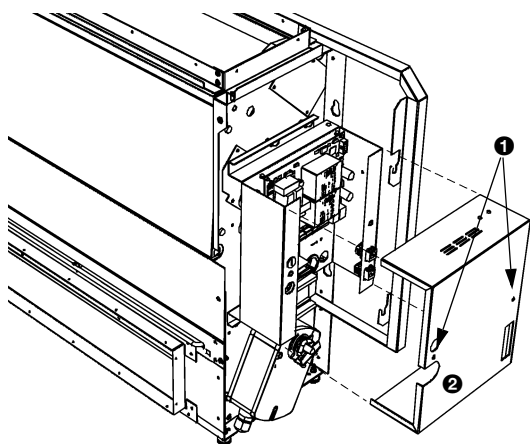
**5.2.3 Opening the electronics compartment**

1. Remove the unit's side panels (see section 5.2.1) or surrounds.
2. Remove the electronics cover:
  - loosen the screw **1** on the front side;
  - slide **2** the cover forward.

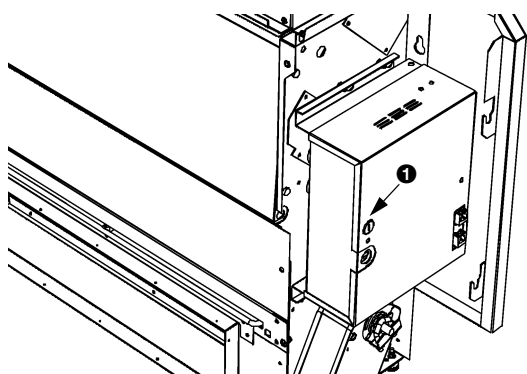
**5.3 Replacing fuses****Transformer fuse**

The fuse holder can be found on the electronics compartment at **1**. The rating is stated next to the fuse holder.

**Operation and/or control unit fuses  
Only for control type I**

The fuse is located on the PCB in the electronics compartment



(This page is intentionally blank.)

(This page is intentionally blank.)

(This page is intentionally blank.)

## ***Declaration of Conformity***

manufacturer: Biddle BV  
address: Markowei 4  
9288 HA Kootsterille  
The Netherlands

We declare that the following product:

product description: Fan Coil Unit  
brand: Biddle  
model: DECO and SL  
type: DECO-50/75/100/125/150  
SL-50/75/100/125/150

In accordance with the following Directives:

2006/95/EC the Low Voltage Directive  
2006/42/EC the Machinery Directive  
2004/108/EC the Electromagnetic Compatibility Directive

Has been designed and manufactured to the following specifications:

EN 61000-6-2 Electromagnetic Compatibility (EMC) -- Part 6-1: Generic standards – Immunity for industrial environments  
EN 61000-6-3 Electromagnetic Compatibility (EMC) -- Part 6-3: Generic standards – Emission standard for residential, commercial and light-industrial environments  
EN 60335-1 Safety of household and similar electrical appliances Part 1: General requirements  
EN 60335-2-30 Safety of household and similar electrical appliances Part 2-30: Particular requirements for room heaters

I hereby declare that the equipment named above has been designed to comply with the relevant sections of the above referenced specifications. The unit complies with all essential requirements of the directives.

signed by: W. de Vries, Managing Director, 2012

