

# DOORFLOW

Air Curtains

**Biddle**



# A SOLUTION FOR EVERY SITUATION

---

The latest development in a long line of market leading air curtains, the DoorFlow has been developed to be not just of minimalist design but also to minimise maintenance, bringing a continuous and consistent long lasting level of performance and maximize energy savings.

---

The Doorflow warms the cold air before it enters the building and prevents the escape of warm air through the open door. By installing the DoorFlow above the door it increases energy efficiency, prevents draught problems and proves that an open door and a comfortable indoor climate can coexist perfectly well.

## FEATURES AND BENEFITS:

- Minimalist design
- Filter free
- Long lasting performance
- Energy saving ECONTROL
- Performance enhancing patented discharge rectifier
- Choice of RAL paint colours
- Water or electric heating
- Suitable for low water temperatures
- Mounting height up to 3.5m
- Four models, four widths and four styles; free hanging, recessed, cassette and single grille cassette

# HOW IT WORKS

---

As with all air curtains from Biddle the DoorFlow uses Biddle's proven, patented rectifier to supply conditioned air at low speed with minimum turbulence, ensuring the air stream reaches the floor and doesn't escape to the outside. Comfort within the entrance area is therefore enhanced without any energy wastage.

---

## APPLICATIONS

Available in a variety of paint finishes, the DoorFlow has a minimalist style, being designed to look good in all types of entrance environment – from fashionable boutiques to schools and colleges. Modular in nature, any number of units can be joined together to create one seamless air curtain covering any door width.

## PATENTED RECTIFIER TECHNOLOGY

So as to minimise turbulence in the discharge airstream, and ensure the air reaches the floor, Biddle have invested heavily in the development of the patented rectifier. This rectifier comprises an optimised number of blades, with a precise relationship between their length and spacing, to create a laminar airstream which reduces turbulence and energy consumption and increases throw for a given air volume.

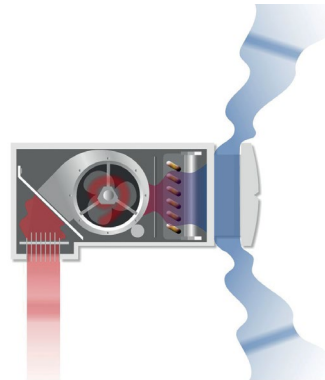

## THERMOGRAPHIC EVIDENCE

The quality and performance of an air curtain can be shown with a thermographic camera. The heat stream, which is invisible to the naked eye, is recorded and depicted with the aid of a special measuring surface and a high resolution thermal imaging camera.

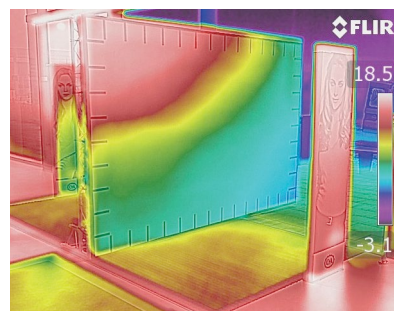

Air curtain off: high degree of air exchange

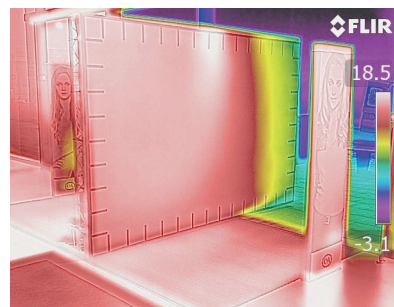

Air curtain on: optimal climate separation



## INSTALLATION AND MAINTENANCE

---

Carefully developed to minimise maintenance, a purpose designed coil/heater battery reduces the build-up of dust and debris between the coil fins to such an extent that filters are no longer necessary. Having no filters means the DoorFlow doesn't just offer minimal maintenance but also provides a continuous and consistent long lasting level of performance.

The DoorFlow air curtain is installed by means of threaded rods and is delivered as standard ready to plug in, including a built-in three-way valve. This makes the unit easy to install. Low voltage cables connect the control panel "plug and play" to the unit. It is also possible to interlink different units in this way.

Units can be specified for free-hanging, cassette or recessed installation and all are compatible with universal fixing systems, allowing longitudinal adjustment for flush fitting.

The separately supplied suspension brackets can be inserted in the recesses in the top of the unit and then fixed to a mounting rail to allow horizontal adjustment. Special brackets are available for wall mounting. A full installer kit with separate grilles is also supplied for recessed applications.

On delivery, all DoorFlow units include detailed installer, control and wiring instructions and maintenance notes.

# CONTROLS

---

## ENERGY SAVING ECONTROL

The new ECONTROL will ensure air curtain performance is optimised whilst minimizing energy usage.

Connecting the ECONTROL to DOORFLOW couldn't be easier-just plug one end of the cable into the air curtain and the other end into the controller.

In 'Auto' mode ECONTROL will automatically adjust the air curtain's heat output to optimize air curtain performance, control the space at these selected set point temperature (range=18-25°C) and minimise energy usage.

In 'Manual' mode ECONTROL simply provides the air curtain with either half heat or full heat.

Regardless of whether the air curtain is in 'Auto' or 'Manual' mode the user can:

- Select fan speed
- Turn the heating off and operate the air curtain as an ambient unit



---

## EXTERNAL CONTROL CONNECTIONS

### REMOTE ENABLE VIA BMS

A volt free BMS enable contact (INHIBIT) is included on each unit as standard. If the terminal is linked the unit will run. If it is open circuit across the terminal the unit will switch off.

### REMOTE HEATING CONTROL VIA BMS

To facilitate fan only operation (i.e. no heating) a 3.3ko resistance should be wired across the INHIBIT terminal.

### FAULT OUTPUT

#### (ELECTRICAL HEATED AIR CURTAINS ONLY)

A fault signal indicator is provided for when the electric elements overheat and the safety cut - out has operated. A healthy system provides a 24V DC signal at the terminals whereas an overheat fault provides 0V DC.

---

## WATER UNITS

The water units of the DoorFlow model are fitted as standard with built-in room temperature control with a three-way valve. The model can optionally be ordered with an external two-way valve. The standard built-in three-way valve is then removed.

## ELECTRIC UNITS

Electric units are delivered as standard with room temperature control.

## OTHER CONTROL OPTIONS

It is also possible to connect a (week) timer, door contact switch, building management system or extra relay for controlling a boiler. With these options, automatic comfort is guaranteed.

# SELECTION

## CORRECT CHOICE OF UNIT ESSENTIAL FOR PERFORMANCE

For optimal functioning of the DoorFlow, selecting the right type of unit(s) is essential. If an air curtain has been selected well it is able to protect the entire width and height of the door opening. The unit must have sufficient heating capacity to be able to bring incoming cold air to a comfortable temperature.

### 1. INSTALLATION HEIGHT AND WIDTH

Based on the installation height (from floor to the bottom of the unit) and the door width, it is easy to select the right air curtain (see selection table). By installing multiple units next to each other, door openings wider than 250cm can be protected.

#### SELECTION TABLE

Type	Door height (cm)	Door width (cm)
S	200-250cm	100 - 150 - 200 - 250
M	250-300cm	100 - 150 - 200 - 250
L	300-350cm	100 - 150 - 200 - 250

### 2. CORRECT INSTALLATION

For the air curtain to function properly, it is important that the distance between the air curtain and the door is as short as possible. Also, the air curtain must be at least as wide as the doorway to prevent cold air bypassing the unit's air stream at the sides.

#### TYPE CODE: DF S-100-H2-F

DF	DoorFlow
<b>Capacity</b>	
S	200-250cm
M	250-300cm
L	300-350cm
<b>Length (cm)</b>	
	100 - 150 - 200 - 250
<b>Coil type</b>	
H2	Hot water heating, 2-row
H4	Hot water heating, 4-row
E	Electrical heating
A	Ambient
<b>Model</b>	
F	Free hanging model
R	Recessed model
C	Cassette models
T	Tourniquet model

## WIRING SCHEMATIC

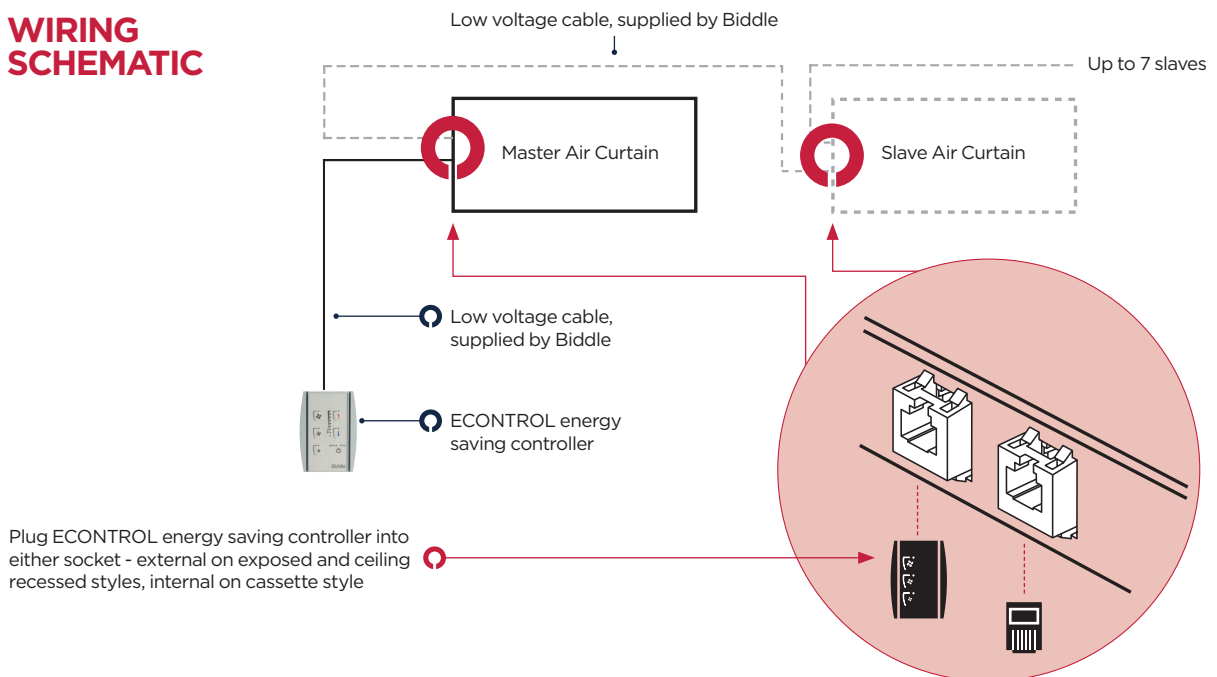

## CONTROLS SCHEMATIC

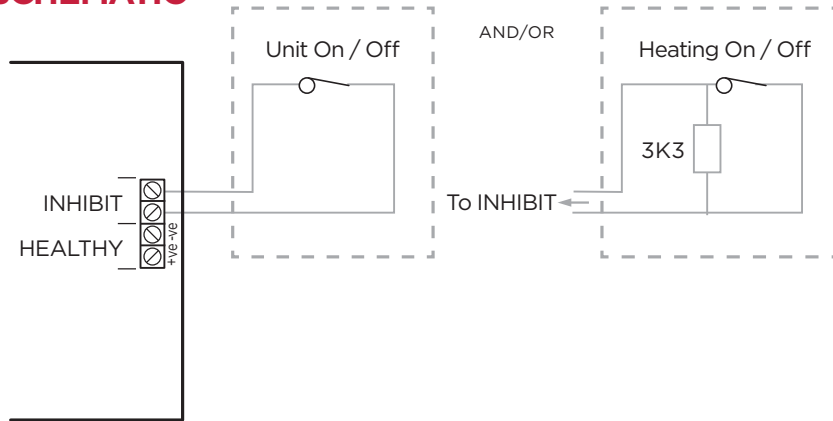

## CIRCULAR DOORWAYS

When an air curtain is to be used in conjunction with revolving doors or any other form of circular doorway we are able to use a variant of the recessed model installed either adjacent to or directly above the door. Given certain key dimensions we manufacture a bespoke discharge grille to fit perfectly with the curvature of the door, and ensure optimum climate separation around the circular doorway.

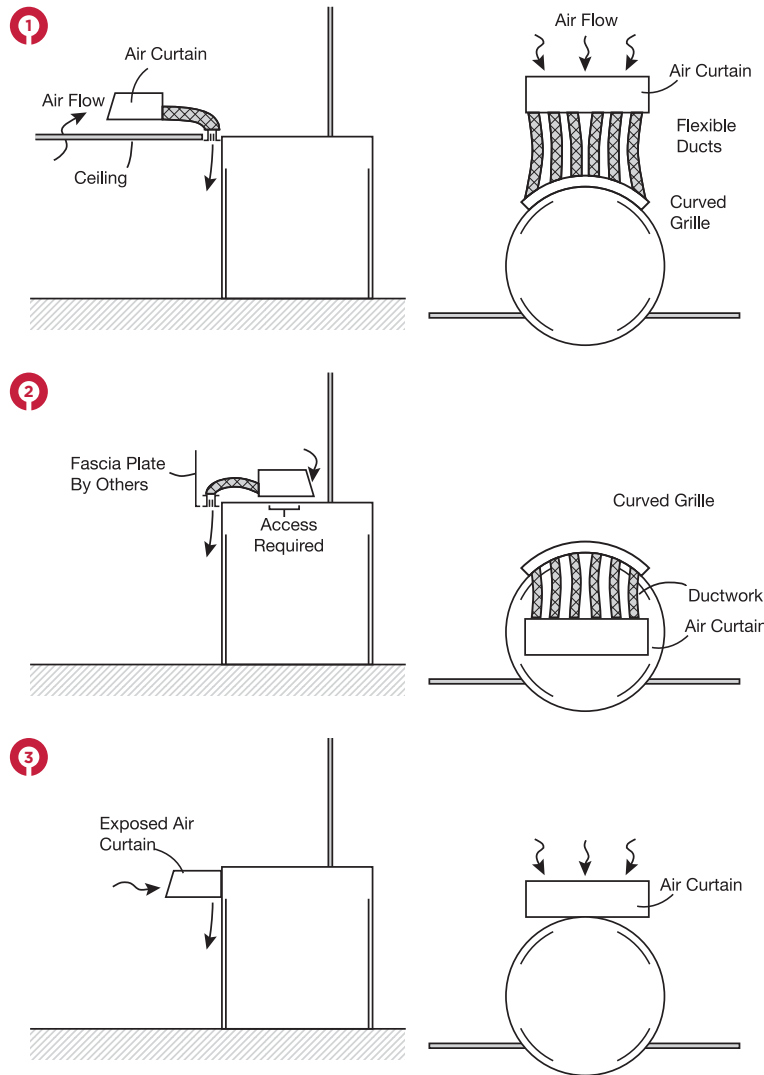
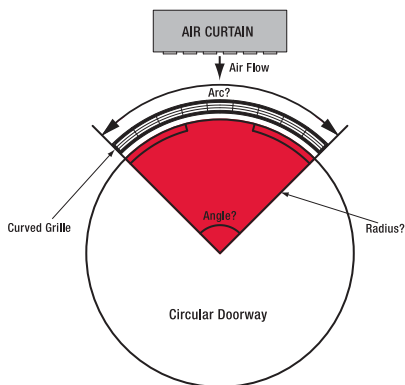

# SPECIFICATIONS

---

## CONTROL & OPERATION

By adjusting heat output and fan speed the ECONTROL ensures air curtain performance is optimised whilst minimising energy usage. It is connected to the unit by a low voltage data cable with a RJ4/4 plug on both ends. Multiple units are also connected in this way. Cables are available in a variety of lengths.

## ELECTRICAL CONNECTIONS

LPHW units are connected to the mains supply by a 2 metre cable. The 3-phase mains supply cable used with electric heated units enters the air curtain via a cable gland on top of the unit and is then connected to a terminal strip within the unit. The water connections and the socket for the RJ4/4 plug are located on top of the unit.

## CASING

The casing is made from zinc plated sheet steel and incorporates an inspection panel. Both the discharge grille, incorporating the patented rectifier, and the inlet grille are made of anodized aluminium. As standard the exposed, ceiling recessed and cassette units are painted white (RAL9016). Alternative colours can be supplied if requested.

## MOTOR/FAN ASSEMBLY

The air curtain is fitted with two or more (depending on size) dual-inlet vibration-free centrifugal fans. Each fan is driven by a suspended rotor motor. The fan casing and impeller are made from either zinc coated steel or plastic, depending on the model. The motors are manufactured according to EN60-335-1, protection class IP44 and insulation class F. They are fitted as standard with thermal contacts which break the circuit if the maximum allowable motor temperature is exceeded.

## HEATER BATTERY

The LPHW coil comprises 3/8" copper pipes and aluminium fins. The water supply connections for the exposed, ceiling recessed and cassette units are 1" BSP female thread and for the single grille cassette unit 3/4" BSP female thread. The test pressure is 9 bars and the maximum operating pressure is 8 bars at 175°C. The electric heating coil is made of U-tube-shaped stainless rods.

## STANDARD DELIVERY

Rectifier technology  
Discharge duct (model R)  
Built-in water side control: three-way valve and actuator (water units)  
Room temperature control  
Power cable, 230 Volts, length 2 metres (excl. electric units)

## OPTIONAL

Two-way control valve (delivered separately)  
Door contact switch  
Wall brackets  
Relay for controlling boiler



# DOORFLOW

Technical Details



# TECHNICAL EXPLANATION

The heating capacities of water units with the two row heating coil are based on a water range of 80/60°C with an air inlet temperature of 20°C, and with the four row heating coil on a water range of 60/40°C with an air inlet temperature of 20°C. With different water and air inlet temperatures, the heating capacity should be multiplied by the factors in the table below.

H2	Air inlet temperature			
	15°C	18°C	20°C	22°C
90/70°C	1,35	1,28	1,23	1,19
82/71°C	1,32	1,24	1,2	1,15
80/60°C	1,12	1,05	(1)	0,95
H4				
70/50°C	1,58	1,46	1,38	1,31
60/40°C	1,2	1,08	(1)	0,92
50/40°C	1,05	0,94	0,86	0,79
50/30°C	0,8	0,68	0,6	0,52

## WATER VOLUME

With water and room temperatures other than the values represented in the tables, the water volume can be roughly calculated using the formula below. The heating capacity should first be recalculated based on the table above.

- $m_w$  = water flow rate [l/h]
- $Q$  = capacity [kW]
- $C_{pw}$  = specific heat of water (=4.18) [kJ/kg°C]
- $\Delta T_w$  = temperature difference water [°C]
- $P_w$  = density of water at 90°C (=0.984) [kg/l]

$$m_w = \frac{Q}{C_{pw} \Delta T_w \rho_w} 3600 \text{ [l/h]}$$

## WATER PRESSURE LOSS

With water temperatures other than 80/60°C (two row heating coil) or 60/40°C (four row heating coil), the water pressure loss can roughly be calculated using the formula below. To do so, the water volume must first be calculated (see left).

- $\Delta P_{w1}$  = water pressure loss, table values [kPa]
- $\Delta P_{w2}$  = water pressure loss [kPa]
- $m_{w1}$  = water pressure loss [l/h]
- $m_{w2}$  = water volume formula [l/h]

$$\Delta p_{w_2} = \Delta p_{w_1} \left( \frac{m_{w_2}}{m_{w_1}} \right)^2 \text{ [kPa]}$$

# TECHNICAL EXPLANATION

## SOUND

The sound data is based on the direct field, in a situation with an open door and a sound absorbing ceiling.

The sound data for different situations can be determined by adding the adjacent values to the table values.

Closed door + 1 - 2 dB(A)

Acoustical "hard" ceiling + 2 - 3 dB(A)

Deviating distances and several units next to each other can be calculated with the table below. Data from the 1m unit, measured at a distance of 3m, is the basic assumption. The factors apply to all types of air curtains.

## CORRECTION FACTORS FOR SOUND PRESSURE IN dB(A)

Distance (m)	Total unit length (m)					
	1	1,5	2	2,5	3	3,5
1	+9,5	+11,3	+12,6	+13,5	+14,3	+15,0
2	+3,5	+5,3	+6,5	+7,5	+8,3	+9,0
3	0	+1,8	+3,0	+4,0	+4,8	+5,4
4	-2,5	-0,7	+0,5	+1,5	+2,3	+2,9
5	-4,4	-2,7	-1,4	-0,5	+0,3	+1,0

# WATER HEATING

## DF S-100-H2

Unit length	m	1		
Door height	m	2 - 2,5		
Electrical supply	V/ph/Hz	230/1/50		
Max. Input current (1 phase)	A	0,96		
Max. Fan power	kW	0,22		
Max. Specific fan power	W/l/s	0,62		
Water flow rate	l/h	261		
Water pressure drop with 3-port valve	kPa	0,31		
Water pressure drop with 2-port valve	kPa	0,26		
Water range	°C	80/60		
Weight F / R / C	kg	31/30/34		
Air inlet temperature	°C		20	
Speed		1	2	3
Discharge air temperature	°C	37,2	35,4	33,8
Air volume	m <sup>3</sup> /h	762	983	1285
Heating capacity	kW	4,4	5,1	6
Sound pressure level at 3m	dB(A)	37	43	50

## DF S-150-H2

Unit length	m	1,5		
Door height	m	2 - 2,5		
Electrical supply	V/ph/Hz	230/1/50		
Max. Input current (1 phase)	A	1,44		
Max. Fan power	kW	0,33		
Max. Specific fan power	W/l/s	0,62		
Water flow rate	l/h	437		
Water pressure drop with 3-port valve	kPa	0,94		
Water pressure drop with 2-port valve	kPa	0,81		
Water range	°C	80/60		
Weight F / R / C	kg	46/45/51		
Air inlet temperature	°C		20	
Speed		1	2	3
Discharge air temperature	°C	38,8	37,1	35,4
Air volume	m <sup>3</sup> /h	1173	1483	1927
Heating capacity	kW	7,4	8,6	10
Sound pressure level at 3m	dB(A)	39	45	52

## DF S-200-H2

Unit length	m	2		
Door height	m	2 - 2,5		
Electrical supply	V/ph/Hz	230/1/50		
Max. Input current (1 phase)	A	1,92		
Max. Fan power	kW	0,44		
Max. Specific fan power	W/l/s	0,62		
Water flow rate	l/h	614		
Water pressure drop with 3-port valve	kPa	1,99		
Water pressure drop with 2-port valve	kPa	1,74		
Water range	°C	80/60		
Weight F / R / C	kg	60/58/66		
Air inlet temperature	°C		20	
Speed		1	2	3
Discharge air temperature	°C	39,8	38	36,2
Air volume	m <sup>3</sup> /h	1544	1971	2570
Heating capacity	kW	10,3	12	14
Sound pressure level at 3m	dB(A)	40	46	53

# WATER HEATING

## DF S-250-H2

Unit length	m	2,5		
Door height	m	2 - 2,5		
Electrical supply	V/ph/Hz	230/1/50		
Max. Input current (1 phase)	A	2,4		
Max. Fan power	kW	0,55		
Max. Specific fan power	W/l/s	0,62		
Water flow rate	l/h	791		
Water pressure drop with 3-port valve	kPa	3,53		
Water pressure drop with 2-port valve	kPa	3,11		
Water range	°C	80/60		
Weight F / R / C	kg	76/74/84		
Air inlet temperature	°C		20	
Speed			1	2
				3
Discharge air temperature	°C	40,4	38,6	36,7
Air volume	m <sup>3</sup> /h	1930	2464	3213
Heating capacity	kW	13,3	15,4	18
Sound pressure level at 3m	dB(A)	41	47	54

## DF M-100-H2

Unit length	m	1		
Door height	m	2.5 - 3		
Electrical supply	V/ph/Hz	230/1/50		
Max. Input current (1 phase)	A	1,44		
Max. Fan power	kW	0,33		
Max. Specific fan power	W/l/s	0,84		
Water flow rate	l/h	275		
Water pressure drop with 3-port valve	kPa	0,34		
Water pressure drop with 2-port valve	kPa	0,29		
Water range	°C	80/60		
Weight F / R / C	kg	35/34/38		
Air inlet temperature	°C		20	
Speed			1	2
				3
Discharge air temperature	°C	35,2	34,2	33,2
Air volume	m <sup>3</sup> /h	1019	1195	1412
Heating capacity	kW	5,2	5,7	6,3
Sound pressure level at 3m	dB(A)	42	46	50

## DF M-150-H2

Unit length	m	1,5		
Door height	m	2.5 - 3		
Electrical supply	V/ph/Hz	230/1/50		
Max. Input current (1 phase)	A	1,92		
Max. Fan power	kW	0,44		
Max. Specific fan power	W/l/s	0,74		
Water flow rate	l/h	463		
Water pressure drop with 3-port valve	kPa	1,05		
Water pressure drop with 2-port valve	kPa	0,9		
Water range	°C	80/60		
Weight F / R / C	kg	51/49/55		
Air inlet temperature	°C		20	
Speed			1	2
				3
Discharge air temperature	°C	37,4	36,1	34,7
Air volume	m <sup>3</sup> /h	1422	1722	2131
Heating capacity	kW	8,4	9,3	10,6
Sound pressure level at 3m	dB(A)	42	47	52

# WATER HEATING

## DF M-200-H2

Unit length	m	2		
Door height	m	2,5 - 3		
Electrical supply	V/ph/Hz	230/1/50		
Max. Input current (1 phase)	A	2,88		
Max. Fan power	kW	0,66		
Max. Specific fan power	W/l/s	0,84		
Water flow rate	l/h	648		
Water pressure drop with 3-port valve	kPa	2,21		
Water pressure drop with 2-port valve	kPa	1,93		
Water range	°C	80/60		
Weight F / R / C	kg	68/66/74		
Air inlet temperature	°C		20	
Speed		1	2	3
Discharge air temperature	°C	37,8	36,7	35,5
Air volume	m <sup>3</sup> /h	2038	2390	2824
Heating capacity	kW	12,2	13,4	14,8
Sound pressure level at 3m	dB(A)	45	49	53

## DF M-250-H2

Unit length	m	2,5		
Door height	m	2,5 - 3		
Electrical supply	V/ph/Hz	230/1/50		
Max. Input current (1 phase)	A	3,36		
Max. Fan power	kW	0,77		
Max. Specific fan power	W/l/s	0,74		
Water flow rate	l/h	862		
Water pressure drop with 3-port valve	kPa	4,17		
Water pressure drop with 2-port valve	kPa	3,67		
Water range	°C	80/60		
Weight F / R / C	kg	84/82/92		
Air inlet temperature	°C		20	
Speed		1	2	3
Discharge air temperature	°C	38,5	37,1	35,7
Air volume	m <sup>3</sup> /h	2489	3014	3729
Heating capacity	kW	15,5	17,4	19,7
Sound pressure level at 3m	dB(A)	46	50	56

## DF L-100-H2

Unit length	m	1		
Door height	m	3 - 3,5		
Electrical supply	V/ph/Hz	230/1/50		
Max. Input current (1 phase)	A	2,52		
Max. Fan power	kW	0,58		
Max. Specific fan power	W/l/s	1,11		
Water flow rate	l/h	321		
Water pressure drop with 3-port valve	kPa	0,46		
Water pressure drop with 2-port valve	kPa	0,39		
Water range	°C	80/60		
Weight F / R / C	kg	33/32/36		
Air inlet temperature	°C		20	
Speed		1	2	3
Discharge air temperature	°C	34,3	32,8	31,6
Air volume	m <sup>3</sup> /h	1172	1498	1877
Heating capacity	kW	5,7	6,5	7,3
Sound pressure level at 3m	dB(A)	41	48	54

# WATER HEATING

## DF L-150-H2

Unit length	m	1,5		
Door height	m	3 - 3,5		
Electrical supply	V/ph/Hz	230/1/50		
Max. Input current (1 phase)	A	3,36		
Max. Fan power	kW	0,79		
Max. Specific fan power	W/l/s	1,08		
Water flow rate	l/h	521		
Water pressure drop with 3-port valve	kPa	1,32		
Water pressure drop with 2-port valve	kPa	1,14		
Water range	°C	80/60		
Weight F / R / C	kg	47/46/52		
Air inlet temperature	°C		20	
Speed			1	2
				3
Discharge air temperature	°C	36,7	35	33,4
Air volume	m <sup>3</sup> /h	1581	2051	2633
Heating capacity	kW	8,9	10,3	11,9
Sound pressure level at 3m	dB(A)	42	48	53

## DF L-200-H2

Unit length	m	2		
Door height	m	3 - 3,5		
Electrical supply	V/ph/Hz	230/1/50		
Max. Input current (1 phase)	A	5,04		
Max. Fan power	kW	1,15		
Max. Specific fan power	W/l/s	1,1		
Water flow rate	l/h	762		
Water pressure drop with 3-port valve	kPa	3,02		
Water pressure drop with 2-port valve	kPa	2,63		
Water range	°C	80/60		
Weight F / R / C	kg	63/61/69		
Air inlet temperature	°C		20	
Speed			1	2
				3
Discharge air temperature	°C	36,8	35,2	33,7
Air volume	m <sup>3</sup> /h	2345	2996	3754
Heating capacity	kW	13,3	15,3	17,4
Sound pressure level at 3m	dB(A)	44	51	57

## DF L-250-H2

Unit length	m	2,5		
Door height	m	3 - 3,5		
Electrical supply	V/ph/Hz	230/1/50		
Max. Input current (1 phase)	A	5,88		
Max. Fan power	kW	1,36		
Max. Specific fan power	W/l/s	1,06		
Water flow rate	l/h	973		
Water pressure drop with 3-port valve	kPa	5,26		
Water pressure drop with 2-port valve	kPa	4,62		
Water range	°C	80/60		
Weight F / R / C	kg	79/76/86		
Air inlet temperature	°C		20	
Speed			1	2
				3
Discharge air temperature	°C	37,7	35,9	34,3
Air volume	m <sup>3</sup> /h	2766	3590	4608
Heating capacity	kW	16,5	19,2	22,2
Sound pressure level at 3m	dB(A)	45	51	57

# WATER HEATING

## DF S-100-H4

Unit length	m	1		
Door height	m	2 - 2,5		
Electrical supply	V/ph/Hz	230/1/50		
Max. Input current (1 phase)	A	0,96		
Max. Fan power	kW	0,22		
Max. Specific fan power	W/l/s	0,62		
Water flow rate	l/h	265		
Water pressure drop with 3-port valve	kPa	0,42		
Water pressure drop with 2-port valve	kPa	0,37		
Water range	°C	60/40		
Weight F / R / C	kg	33/32/36		
Air inlet temperature	°C		20	
Speed		1	2	3
Discharge air temperature	°C	37,1	35,6	34,1
Air volume	m <sup>3</sup> /h	762	983	1285
Heating capacity	kW	4,4	5,2	6,1
Sound pressure level at 3m	dB(A)	37	43	50

## DF S-150-H4

Unit length	m	1,5		
Door height	m	2 - 2,5		
Electrical supply	V/ph/Hz	230/1/50		
Max. Input current (1 phase)	A	1,44		
Max. Fan power	kW	0,33		
Max. Specific fan power	W/l/s	0,62		
Water flow rate	l/h	441		
Water pressure drop with 3-port valve	kPa	1,33		
Water pressure drop with 2-port valve	kPa	1,19		
Water range	°C	60/40		
Weight F / R / C	kg	49/48/54		
Air inlet temperature	°C		20	
Speed		1	2	3
Discharge air temperature	°C	38,6	37,2	35,7
Air volume	m <sup>3</sup> /h	1173	1483	1927
Heating capacity	kW	7,4	8,6	10,2
Sound pressure level at 3m	dB(A)	39	45	52

## DF S-200-H4

Unit length	m	2		
Door height	m	2 - 2,5		
Electrical supply	V/ph/Hz	230/1/50		
Max. Input current (1 phase)	A	1,92		
Max. Fan power	kW	0,44		
Max. Specific fan power	W/l/s	0,62		
Water flow rate	l/h	618		
Water pressure drop with 3-port valve	kPa	2,91		
Water pressure drop with 2-port valve	kPa	2,65		
Water range	°C	60/40		
Weight F / R / C	kg	64/62/70		
Air inlet temperature	°C		20	
Speed		1	2	3
Discharge air temperature	°C	39,5	38	36,4
Air volume	m <sup>3</sup> /h	1544	1971	2570
Heating capacity	kW	10,2	12	14,2
Sound pressure level at 3m	dB(A)	40	46	53



# WATER HEATING

## DF S-250-H4

Unit length	m	2,5		
Door height	m	2 - 2,7		
Electrical supply	V/ph/Hz	230/1/50		
Max. Input current (1 phase)	A	2,4		
Max. Fan power	kW	0,55		
Max. Specific fan power	W/l/s	0,62		
Water flow rate	l/h	795		
Water pressure drop with 3-port valve	kPa	5,3		
Water pressure drop with 2-port valve	kPa	4,87		
Water range	°C	60/40		
Weight F / R / C	kg	81/79/89		
Air inlet temperature	°C		20	
Speed		1	2	3
Discharge air temperature	°C	40	38,5	36,9
Air volume	m <sup>3</sup> /h	1930	2464	3213
Heating capacity	kW	13	15,4	18,3
Sound pressure level at 3m	dB(A)	41	47	54

## DF M-100-H4

Unit length	m	1		
Door height	m	2,5 - 3		
Electrical supply	V/ph/Hz	230/1/50		
Max. Input current (1 phase)	A	1,44		
Max. Fan power	kW	0,33		
Max. Specific fan power	W/l/s	0,84		
Water flow rate	l/h	280		
Water pressure drop with 3-port valve	kPa	0,47		
Water pressure drop with 2-port valve	kPa	0,41		
Water range	°C	60/40		
Weight F / R / C	kg	37/36/40		
Air inlet temperature	°C		20	
Speed		1	2	3
Discharge air temperature	°C	35,4	34,5	33,6
Air volume	m <sup>3</sup> /h	1019	1195	1412
Heating capacity	kW	5,3	5,8	6,5
Sound pressure level at 3m	dB(A)	42	46	50

## DF M-150-H4

Unit length	m	1,5		
Door height	m	2,5 - 3		
Electrical supply	V/ph/Hz	230/1/50		
Max. Input current (1 phase)	A	1,92		
Max. Fan power	kW	0,44		
Max. Specific fan power	W/l/s	0,74		
Water flow rate	l/h	470		
Water pressure drop with 3-port valve	kPa	1,49		
Water pressure drop with 2-port valve	kPa	1,35		
Water range	°C	60/40		
Weight F / R / C	kg	53/52/58		
Air inlet temperature	°C		20	
Speed		1	2	3
Discharge air temperature	°C	37,4	36,3	35,1
Air volume	m <sup>3</sup> /h	1422	1722	2131
Heating capacity	kW	8,4	9,5	10,8
Sound pressure level at 3m	dB(A)	42	47	52

# WATER HEATING

## DF M-200-H4

Unit length	m	2		
Door height	m	2,5 - 3		
Electrical supply	V/ph/Hz	230/1/50		
Max. Input current (1 phase)	A	2,88		
Max. Fan power	kW	0,66		
Max. Specific fan power	W/l/s	0,84		
Water flow rate	l/h	656		
Water pressure drop with 3-port valve	kPa	3,26		
Water pressure drop with 2-port valve	kPa	2,96		
Water range	°C	60/40		
Weight F / R / C	kg	72/70/78		
Air inlet temperature	°C		20	
Speed		1	2	3
Discharge air temperature	°C	37,8	36,9	35,9
Air volume	m <sup>3</sup> /h	2038	2390	2824
Heating capacity	kW	12,2	13,6	15,1
Sound pressure level at 3m	dB(A)	45	49	53

## DF M-250-H4

Unit length	m	2,5		
Door height	m	2,5 - 3		
Electrical supply	V/ph/Hz	230/1/50		
Max. Input current (1 phase)	A	3,36		
Max. Fan power	kW	0,77		
Max. Specific fan power	W/l/s	0,74		
Water flow rate	l/h	874		
Water pressure drop with 3-port valve	kPa	6,33		
Water pressure drop with 2-port valve	kPa	5,82		
Water range	°C	60/40		
Weight F / R / C	kg	89/87/97		
Air inlet temperature	°C		20	
Speed		1	2	3
Discharge air temperature	°C	38,5	37,3	36
Air volume	m <sup>3</sup> /h	2489	3014	3729
Heating capacity	kW	15,5	17,6	20,1
Sound pressure level at 3m	dB(A)	46	50	56

## DF L-100-H4

Unit length	m	1		
Door height	m	3 - 3,5		
Electrical supply	V/ph/Hz	230/1/50		
Max. Input current (1 phase)	A	2,52		
Max. Fan power	kW	0,58		
Max. Specific fan power	W/l/s	1,11		
Water flow rate	l/h	331		
Water pressure drop with 3-port valve	kPa	0,64		
Water pressure drop with 2-port valve	kPa	0,57		
Water range	°C	60/40		
Weight F / R / C	kg	35/33/38		
Air inlet temperature	°C		20	
Speed		1	2	3
Discharge air temperature	°C	34,6	33,3	32,1
Air volume	m <sup>3</sup> /h	1172	1498	1877
Heating capacity	kW	5,8	6,7	7,6
Sound pressure level at 3m	dB(A)	41	48	54

# WATER HEATING

## DF L-150-H4

Unit length	m	1,5		
Door height	m	3 - 3,5		
Electrical supply	V/ph/Hz	230/1/50		
Max. Input current (1 phase)	A	3,36		
Max. Fan power	kW	0,79		
Max. Specific fan power	W/l/s	1,08		
Water flow rate	l/h	535		
Water pressure drop with 3-port valve	kPa	1,91		
Water pressure drop with 2-port valve	kPa	1,72		
Water range	°C	60/40		
Weight F / R / C	kg	50/49/55		
Air inlet temperature	°C		20	
Speed		1	2	3
Discharge air temperature	°C	36,8	35,3	33,9
Air volume	m <sup>3</sup> /h	1581	2051	2633
Heating capacity	kW	9	10,6	12,3
Sound pressure level at 3m	dB(A)	42	48	53

## DF L-200-H4

Unit length	m	2		
Door height	m	3 - 3,5		
Electrical supply	V/ph/Hz	230/1/50		
Max. Input current (1 phase)	A	5,04		
Max. Fan power	kW	1,15		
Max. Specific fan power	W/l/s	1,1		
Water flow rate	l/h	782		
Water pressure drop with 3-port valve	kPa	4,54		
Water pressure drop with 2-port valve	kPa	4,13		
Water range	°C	60/40		
Weight F / R / C	kg	67/65/73		
Air inlet temperature	°C		20	
Speed		1	2	3
Discharge air temperature	°C	37	35,5	34,3
Air volume	m <sup>3</sup> /h	2345	2996	3754
Heating capacity	kW	13,4	15,7	18
Sound pressure level at 3m	dB(A)	44	51	57

## DF L-250-H4

Unit length	m	2,5		
Door height	m	3 - 3,5		
Electrical supply	V/ph/Hz	230/1/50		
Max. Input current (1 phase)	A	5,88		
Max. Fan power	kW	1,36		
Max. Specific fan power	W/l/s	1,06		
Water flow rate	l/h	997		
Water pressure drop with 3-port valve	kPa	8,12		
Water pressure drop with 2-port valve	kPa	7,44		
Water range	°C	60/40		
Weight F / R / C	kg	84/81/91		
Air inlet temperature	°C		20	
Speed		1	2	3
Discharge air temperature	°C	37,8	36,3	34,8
Air volume	m <sup>3</sup> /h	2766	3590	4608
Heating capacity	kW	16,6	19,7	23
Sound pressure level at 3m	dB(A)	45	51	57

# ELECTRICAL HEATING

## DF S-100-E

Unit length	m	1		
Door height	m	2 - 2,5		
Electrical supply	V/ph/Hz	400/3/50		
Max. Input current (1 phase)	A	0,96		
Max. Current consumption (3 phase)	A	8,2		
Max. Fan power	kW	0,22		
Max. Power consumption, heating	kW	5		
Max. Specific fan power	W/l/s	0,62		
Weight F / R / C	kg	35/34/37		
Air inlet temperature	°C		20	
Speed		1	2	3
Discharge air temperature	°C	38,6	34,4	31
Air volume	m <sup>3</sup> /h	762	983	1285
Heating capacity	kW	4,75	4,75	4,75
Sound pressure level at 3m	dB(A)	37	43	50

## DF S-150-E

Unit length	m	1,5		
Door height	m	2 - 2,5		
Electrical supply	V/ph/Hz	400/3/50		
Max. Input current (1 phase)	A	1,44		
Max. Current consumption (3 phase)	A	15,94		
Max. Fan power	kW	0,33		
Max. Power consumption, heating	kW	10		
Max. Specific fan power	W/l/s	0,62		
Weight F / R / C	kg	53/52/56		
Air inlet temperature	°C		20	
Speed		1	2	3
Discharge air temperature	°C	44,2	39,2	34,7
Air volume	m <sup>3</sup> /h	1173	1483	1927
Heating capacity	kW	9,5	9,5	9,5
Sound pressure level at 3m	dB(A)	39	45	52

## DF S-200-E

Unit length	m	2		
Door height	m	2 - 2,5		
Electrical supply	V/ph/Hz	400/3/50		
Max. Input current (1 phase)	A	1,92		
Max. Current consumption (3 phase)	A	23,66		
Max. Fan power	kW	0,44		
Max. Power consumption, heating	kW	15		
Max. Specific fan power	W/l/s	0,62		
Weight F / R / C	kg	69/67/73		
Air inlet temperature	°C		20	
Speed		1	2	3
Discharge air temperature	°C	47,6	41,6	36,6
Air volume	m <sup>3</sup> /h	1544	1971	2570
Heating capacity	kW	14,25	14,25	14,25
Sound pressure level at 3m	dB(A)	40	46	53

# ELECTRICAL HEATING

## DF S-250-E

Unit length	m	2,5		
Door height	m	2 - 2,5		
Electrical supply	V/ph/Hz	400/3/50		
Max. Input current (1 phase)	A	2,4		
Max. Current consumption (3 phase)	A	24,14		
Max. Fan power	kW	0,55		
Max. Power consumption, heating	kW	15		
Max. Specific fan power	W/l/s	0,62		
Weight F / R / C	kg	88/86/93		
Air inlet temperature	°C		20	
Speed		1	2	3
Discharge air temperature	°C	42,1	37,3	33,3
Air volume	m <sup>3</sup> /h	1930	2464	3213
Heating capacity	kW	14,25	14,25	14,25
Sound pressure level at 3m	dB(A)	41	47	54

## DF M-100-E

Unit length	m	1		
Door height	m	2,5 - 3		
Electrical supply	V/ph/Hz	400/3/50		
Max. Input current (1 phase)	A	1,44		
Max. Current consumption (3 phase)	A	15,94		
Max. Fan power	kW	0,33		
Max. Power consumption, heating	kW	10		
Max. Specific fan power	W/l/s	0,84		
Weight F / R / C	kg	39/38/41		
Air inlet temperature	°C		20	
Speed		1	2	3
Discharge air temperature	°C	47,9	43,8	40,1
Air volume	m <sup>3</sup> /h	1019	1195	1412
Heating capacity	kW	9,5	9,5	9,5
Sound pressure level at 3m	dB(A)	42	46	50

## DF M-150-E

Unit length	m	1,5		
Door height	m	2,5 - 3		
Electrical supply	V/ph/Hz	400/3/50		
Max. Input current (1 phase)	A	1,92		
Max. Current consumption (3 phase)	A	23,66		
Max. Fan power	kW	0,44		
Max. Power consumption, heating	kW	15		
Max. Specific fan power	W/l/s	0,74		
Weight F / R / C	kg	57/56/60		
Air inlet temperature	°C		20	
Speed		1	2	3
Discharge air temperature	°C	50	44,7	40
Air volume	m <sup>3</sup> /h	1422	1722	2131
Heating capacity	kW	14,25	14,25	14,25
Sound pressure level at 3m	dB(A)	42	47	52

# ELECTRICAL HEATING

## DF M-200-E

Unit length	m	2		
Door height	m	2,5 - 3		
Electrical supply	V/ph/Hz	400/3/50		
Max. Input current (1 phase)	A	2,88		
Max. Current consumption (3 phase)	A	31,86		
Max. Fan power	kW	0,66		
Max. Power consumption, heating	kW	20		
Max. Specific fan power	W/l/s	0,84		
Weight F / R / C	kg	77/75/81		
Air inlet temperature	°C		20	
Speed		1	2	3
Discharge air temperature	°C	47,9	43,8	40,1
Air volume	m <sup>3</sup> /h	2038	2390	2824
Heating capacity	kW	19	19	19
Sound pressure level at 3m	dB(A)	45	49	53

## DF M-250-E

Unit length	m	2,5		
Door height	m	2,5 - 3		
Electrical supply	V/ph/Hz	400/3/50		
Max. Input current (1 phase)	A	3,36		
Max. Current consumption (3 phase)	A	39,59		
Max. Fan power	kW	0,77		
Max. Power consumption, heating	kW	25		
Max. Specific fan power	W/l/s	0,74		
Weight F / R / C	kg	96/94/101		
Air inlet temperature	°C		20	
Speed		1	2	3
Discharge air temperature	°C	48,5	43,6	39
Air volume	m <sup>3</sup> /h	2489	3014	3729
Heating capacity	kW	23,75	23,75	23,75
Sound pressure level at 3m	dB(A)	46	50	56

## DF L-100-E

Unit length	m	1		
Door height	m	3 - 3,5		
Electrical supply	V/ph/Hz	400/3/50		
Max. Input current (1 phase)	A	2,52		
Max. Current consumption (3 phase)	A	17,02		
Max. Fan power	kW	0,58		
Max. Power consumption, heating	kW	10		
Max. Specific fan power	W/l/s	1,11		
Weight F / R / C	kg	37/36/39		
Air inlet temperature	°C		20	
Speed		1	2	3
Discharge air temperature	°C	44,2	39	35,1
Air volume	m <sup>3</sup> /h	1172	1498	1877
Heating capacity	kW	9,5	9,5	9,5
Sound pressure level at 3m	dB(A)	41	48	54

# ELECTRICAL HEATING

## DF L-150-E

Unit length	m	1,5		
Door height	m	3 - 3,5		
Electrical supply	V/ph/Hz	400/3/50		
Max. Input current (1 phase)	A	3,36		
Max. Current consumption (3 phase)	A	25,1		
Max. Fan power	kW	0,79		
Max. Power consumption, heating	kW	15		
Max. Specific fan power	W/l/s	1,08		
Weight F / R / C	kg	54/53/57		
Air inlet temperature	°C		20	
Speed		1	2	3
Discharge air temperature	°C	46,9	40,8	36,2
Air volume	m <sup>3</sup> /h	1581	2051	2633
Heating capacity	kW	14,25	14,25	14,25
Sound pressure level at 3m	dB(A)	42	48	53

## DF L-200-E

Unit length	m	2		
Door height	m	3 - 3,5		
Electrical supply	V/ph/Hz	400/3/50		
Max. Input current (1 phase)	A	5,04		
Max. Current consumption (3 phase)	A	34,02		
Max. Fan power	kW	1,15		
Max. Power consumption, heating	kW	20		
Max. Specific fan power	W/l/s	1,1		
Weight F / R / C	kg	73/71/76		
Air inlet temperature	°C		20	
Speed		1	2	3
Discharge air temperature	°C	44,2	39	35,1
Air volume	m <sup>3</sup> /h	2345	2996	3754
Heating capacity	kW	19	19	19
Sound pressure level at 3m	dB(A)	44	51	57

## DF L-250-E

Unit length	m	2,5		
Door height	m	3 - 3,5		
Electrical supply	V/ph/Hz	400/3/50		
Max. Input current (1 phase)	A	5,88		
Max. Current consumption (3 phase)	A	42,11		
Max. Fan power	kW	1,36		
Max. Power consumption, heating	kW	25		
Max. Specific fan power	W/l/s	1,06		
Weight F / R / C	kg	91/89/95		
Air inlet temperature	°C		20	
Speed		1	2	3
Discharge air temperature	°C	45,7	39,8	35,4
Air volume	m <sup>3</sup> /h	2766	3590	4608
Heating capacity	kW	23,75	23,75	23,75
Sound pressure level at 3m	dB(A)	45	51	57

# AMBIENT HEATING

## DF S-100-A

Unit length	m	1		
Door height	m	2 - 2,5		
Electrical supply	V/ph/Hz	230/1/50		
Max. Input current (1 phase)	A	0,96		
Max. Fan power	kW	0,22		
Max. Specific fan power	W/l/s	0,62		
Weight F / R / C	kg	29/28/31		
<b>Speed</b>		<b>1</b>	<b>2</b>	<b>3</b>
Air volume	m <sup>3</sup> /h	762	983	1285
Sound pressure level at 3m	dB(A)	37	43	50

## DF S-150-A

Unit length	m	1,5		
Door height	m	2 - 2,5		
Electrical supply	V/ph/Hz	230/1/50		
Max. Input current (1 phase)	A	1,44		
Max. Fan power	kW	0,33		
Max. Specific fan power	W/l/s	0,62		
Weight F / R / C	kg	45/44/48		
<b>Speed</b>		<b>1</b>	<b>2</b>	<b>3</b>
Air volume	m <sup>3</sup> /h	1173	1483	1927
Sound pressure level at 3m	dB(A)	39	45	52

## DF S-200-A

Unit length	m	2		
Door height	m	2 - 2,5		
Electrical supply	V/ph/Hz	230/1/50		
Max. Input current (1 phase)	A	1,92		
Max. Fan power	kW	0,44		
Max. Specific fan power	W/l/s	0,62		
Weight F / R / C	kg	58/56/62		
<b>Speed</b>		<b>1</b>	<b>2</b>	<b>3</b>
Air volume	m <sup>3</sup> /h	1544	1971	2570
Sound pressure level at 3m	dB(A)	40	46	53

## DF S-250-A

Unit length	m	2,5		
Door height	m	2 - 2,5		
Electrical supply	V/ph/Hz	230/1/50		
Max. Input current (1 phase)	A	2,4		
Max. Fan power	kW	0,55		
Max. Specific fan power	W/l/s	0,62		
Weight F / R / C	kg	73/71/78		
<b>Speed</b>		<b>1</b>	<b>2</b>	<b>3</b>
Air volume	m <sup>3</sup> /h	1930	2464	3213
Sound pressure level at 3m	dB(A)	41	47	54



# AMBIENT HEATING

## DF M-100-A

Unit length	m	1		
Door height	m	2,5 - 3		
Electrical supply	V/ph/Hz	230/1/50		
Max. Input current (1 phase)	A	1,44		
Max. Fan power	kW	0,33		
Max. Specific fan power	W/l/s	0,84		
Weight F / R / C	kg	33/32/35		
Speed		1	2	3
Air volume	m <sup>3</sup> /h	1019	1195	1412
Sound pressure level at 3m	dB(A)	42	46	50

## DF M-150-A

Unit length	m	1,5		
Door height	m	2,5 - 3		
Electrical supply	V/ph/Hz	230/1/50		
Max. Input current (1 phase)	A	1,92		
Max. Fan power	kW	0,44		
Max. Specific fan power	W/l/s	0,74		
Weight F / R / C	kg	49/48/52		
Speed		1	2	3
Air volume	m <sup>3</sup> /h	1422	1722	2131
Sound pressure level at 3m	dB(A)	42	47	52

## DF M-200-A

Unit length	m	2		
Door height	m	2,5 - 3		
Electrical supply	V/ph/Hz	230/1/50		
Max. Input current (1 phase)	A	2,88		
Max. Fan power	kW	0,66		
Max. Specific fan power	W/l/s	0,84		
Weight F / R / C	kg	66/64/70		
Speed		1	2	3
Air volume	m <sup>3</sup> /h	2038	2390	2824
Sound pressure level at 3m	dB(A)	45	49	53

## DF M-250-A

Unit length	m	2,5		
Door height	m	2,5 - 3		
Electrical supply	V/ph/Hz	230/1/50		
Max. Input current (1 phase)	A	3,36		
Max. Fan power	kW	0,77		
Max. Specific fan power	W/l/s	0,74		
Weight F / R / C	kg	81/79/86		
Speed		1	2	3
Air volume	m <sup>3</sup> /h	2489	3014	3729
Sound pressure level at 3m	dB(A)	46	50	56

# AMBIENT HEATING

## DF L-100-A

Unit length	m	1		
Door height	m	3 - 3,5		
Electrical supply	V/ph/Hz	230/1/50		
Max. Input current (1 phase)	A	2,52		
Max. Fan power	kW	0,58		
Max. Specific fan power	W/l/s	1,11		
Weight F / R / C	kg	31/30/33		
<b>Speed</b>		<b>1</b>	<b>2</b>	<b>3</b>
Air volume	m <sup>3</sup> /h	1172	1498	1877
Sound pressure level at 3m	dB(A)	41	48	54

## DF L-150-A

Unit length	m	1,5		
Door height	m	3 - 3,5		
Electrical supply	V/ph/Hz	230/1/50		
Max. Input current (1 phase)	A	3,36		
Max. Fan power	kW	0,79		
Max. Specific fan power	W/l/s	1,08		
Weight F / R / C	kg	46/45/49		
<b>Speed</b>		<b>1</b>	<b>2</b>	<b>3</b>
Air volume	m <sup>3</sup> /h	1581	2051	2633
Sound pressure level at 3m	dB(A)	42	48	53

## DF L-200-A

Unit length	m	2		
Door height	m	3 - 3,5		
Electrical supply	V/ph/Hz	230/1/50		
Max. Input current (1 phase)	A	5,04		
Max. Fan power	kW	1,15		
Max. Specific fan power	W/l/s	1,1		
Weight F / R / C	kg	62/60/65		
<b>Speed</b>		<b>1</b>	<b>2</b>	<b>3</b>
Air volume	m <sup>3</sup> /h	2345	2996	3754
Sound pressure level at 3m	dB(A)	44	51	57

## DF L-250-A

Unit length	m	2,5		
Door height	m	3 - 3,5		
Electrical supply	V/ph/Hz	230/1/50		
Max. Input current (1 phase)	A	5,88		
Max. Fan power	kW	1,36		
Max. Specific fan power	W/l/s	1,06		
Weight F / R / C	kg	76/74/80		
<b>Speed</b>		<b>1</b>	<b>2</b>	<b>3</b>
Air volume	m <sup>3</sup> /h	2766	3590	4608
Sound pressure level at 3m	dB(A)	45	51	57

# FREE HANGING UNITS STYLE F

## DIMENSIONAL DRAWINGS

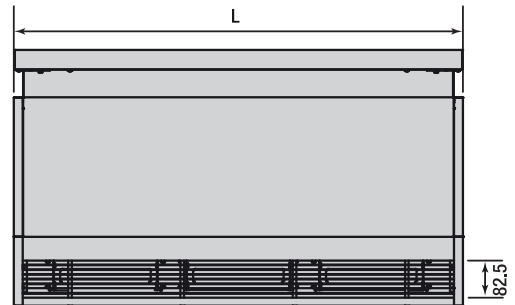
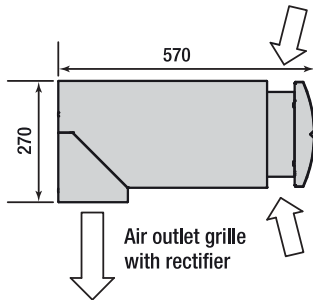
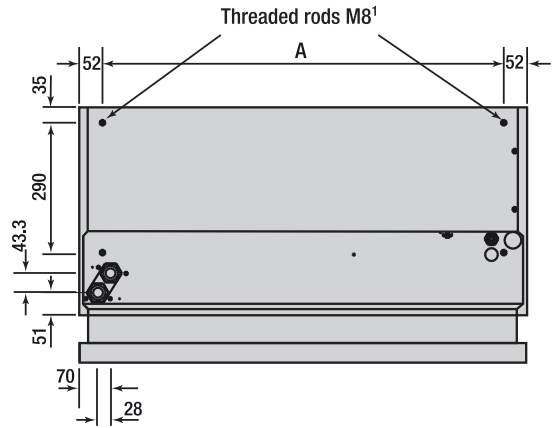
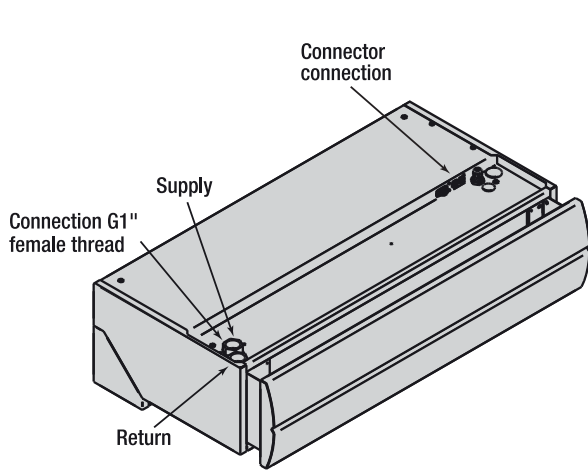

Type	L	A
DF S/M/L	1000	896
	1500	1396
	2000	1896
	2500	2396

1. The 1000, 1500 and 2000mm versions feature a 4 x M8 internal thread, while the 2500mm version has a 6 x M8 internal thread

# CEILING RECESSED UNITS STYLE R

## DIMENSIONAL DRAWINGS

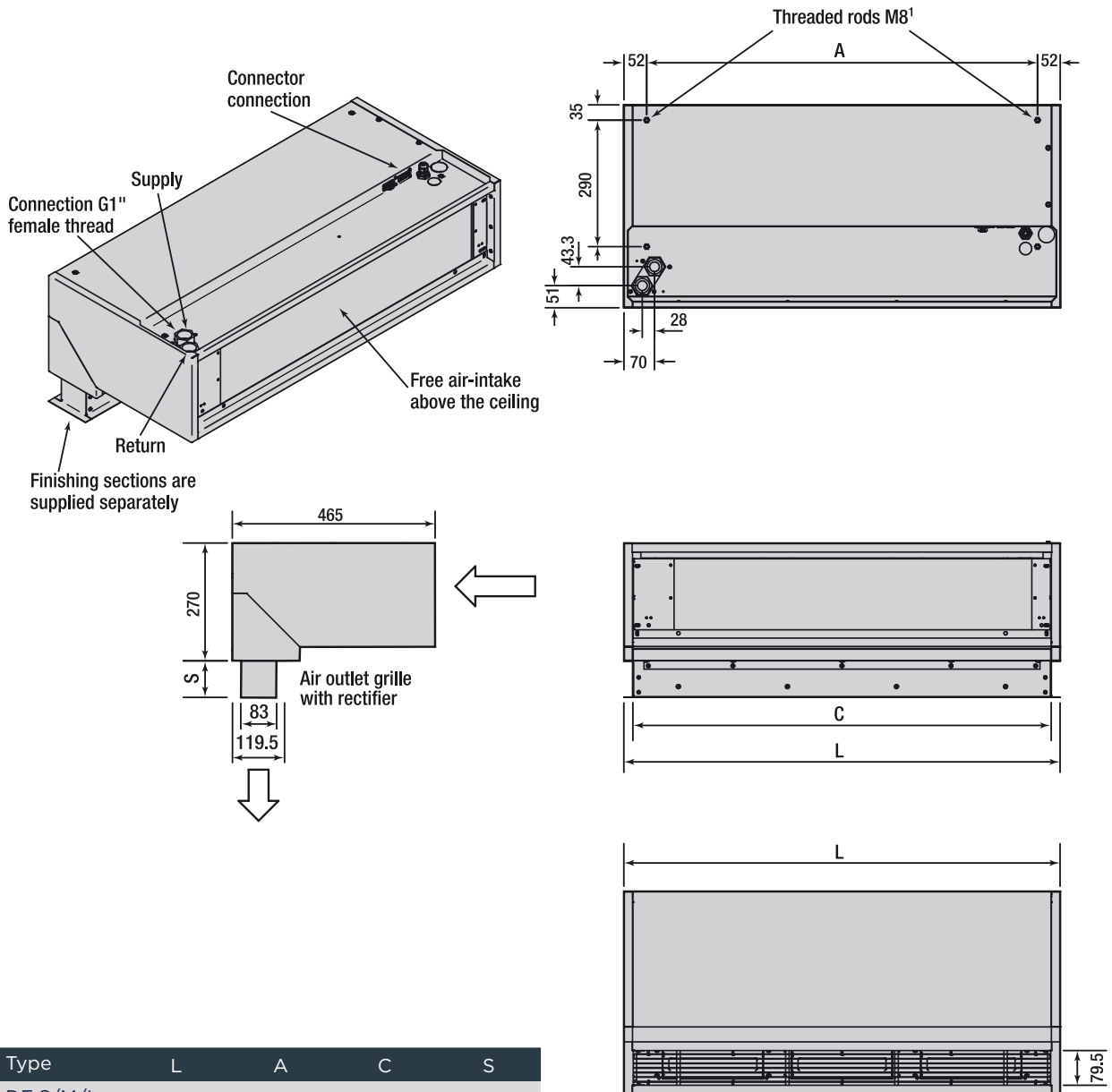

Type	L	A	C	S
DF S/M/L	1000	896	960	50-115
	1500	1396	1460	50-115
	2000	1896	1960	50-115
	2500	2396	2460	50-115

- Daylight openings (if cover mouldings are used): -for air discharge 92 x (C+8) mm.
- For safety reasons electrical heated and ambient units come with a guard grille.
- 1. The 1000, 1500 and 2000mm versions feature a 4 x M8 internal thread, while the 2500mm version has a 6 x M8 internal thread

# CASSETTE UNITS STYLE C

## DIMENSIONAL DRAWINGS

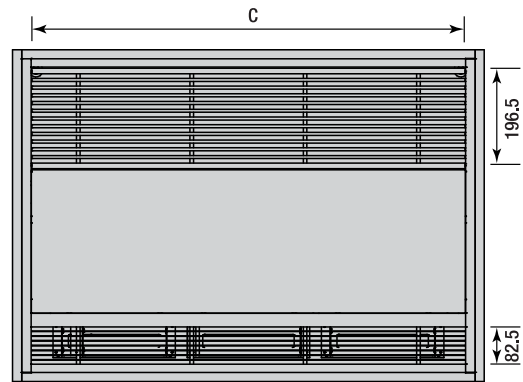
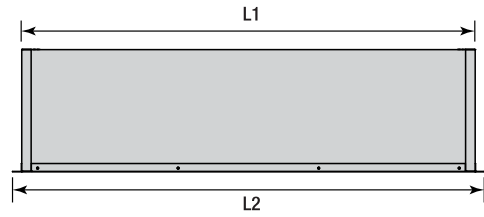
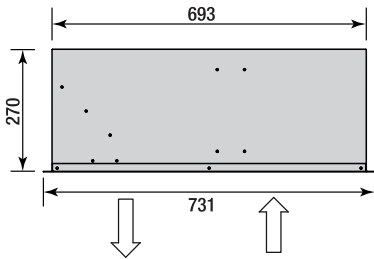
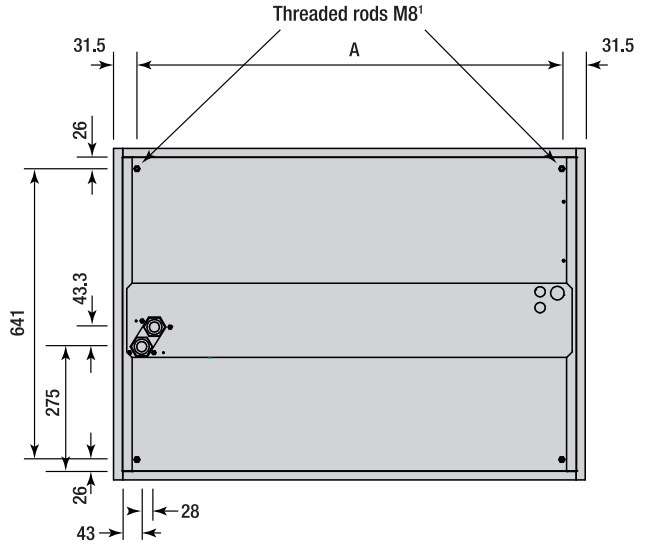
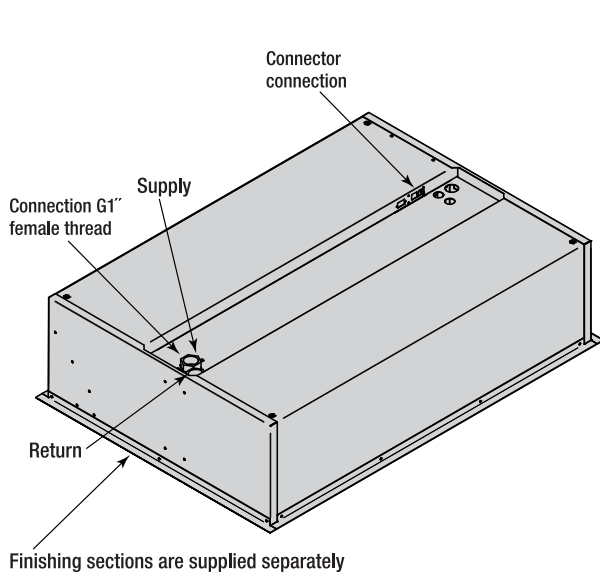

Type	L1	L2	A	C
DF S/M/L	1000	1040	937	958
	1500	1540	1437	1458
	2000	2040	1937	1958
	2500	2540	2437	2458

○ Daylight openings (if cover mouldings are used): -for air discharge (L1 + 8) x 701mm.

1. The 1000, 1500 and 2000mm versions feature a 4 x M8 internal thread, while the 2500mm version has a 6 x M8 internal thread

# TOURNIQUET MODEL

## DIMENSIONAL DRAWINGS

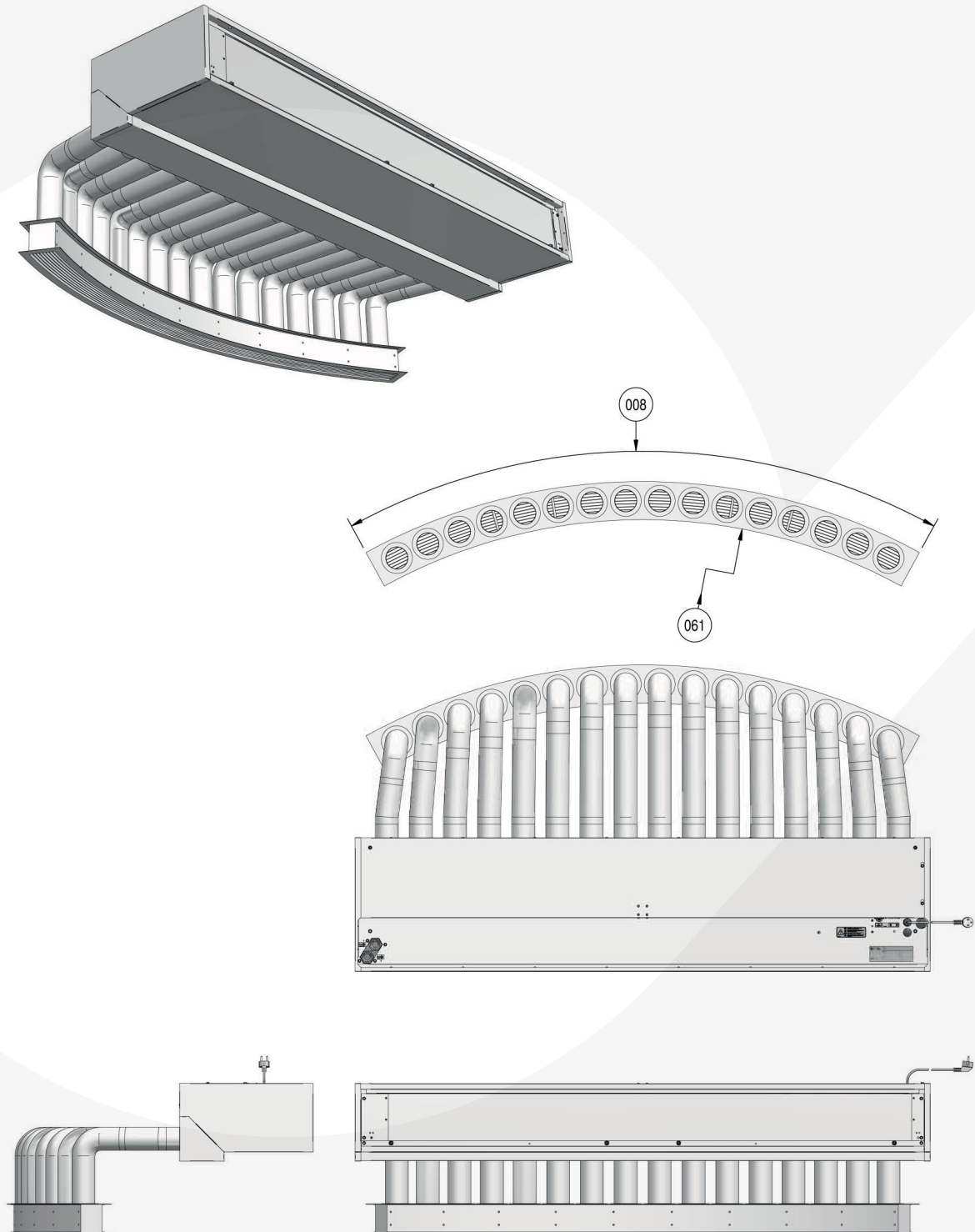

- For a tourniquet air curtain to align with the curve of a revolving door, two measurements are required: the angle and the radius (R).
- For the dimensions of the air curtain, please see the dimensional sketch of the recessed model (R).
- The choice of unit is based on the extended length of the tourniquet.



**BIDDLE AIR SYSTEMS**

St. Mary's Road  
Nuneaton  
Warwickshire  
CV11 5AU

**T** +44 (0) 2476 384 233  
**E** sales@biddle-air.co.uk  
**www.biddle-air.co.uk**



**Biddle**

Every effort has been made to ensure descriptions are correct at the time of print.  
Errors and omissions excepted. DOORFLOW|V2|08|2022