

DECO

Fan Coil Units



Biddle



COMFORTABLE INDOOR CLIMATE

A pleasant work and living environment is determined to a large degree by the quality of the indoor climate. The Biddle DECO fan coil unit gives you optimum control of the indoor climate by heating, cooling and/or ventilating the room.

The DECO is a quiet unit, which can be positioned in the room to ensure the discharged air stream is distributed evenly across the room without causing a nuisance to the people in it.

Biddle DECO fan coil units allow people to control the climate per room. Users can simply regulate the room temperature and the fresh air themselves to ensure optimum climate comfort.

COMFORT WHERE YOU NEED IT

The Biddle fan coil unit features an innovative adjustable discharge grille (Multi Vector Technology), which is made up of a number of stacked sheets with a hole pattern. Using this discharge grille, the direction of the air can be regulated. To cool a room, the air is

blown into the room differently than when heating it. The grille enables the user to direct the air to or from the place where he or she is working, thus providing “comfort where you need it”.

COMPREHENSIVE RANGE

The DECO fan coil unit is available in 5 unit sizes: Deco 50, DECO 75, DECO 100, DECO 125 and DECO 150. The air flow rates of these types range from 140 – 1800 m³/h. The DECO can heat, cool or ventilate the room and is available with and without casing. The model with casing is available as a wall model (F) or as a ceiling model (C) and can be free standing or suspended.

The units available are:

- **STYLISH MODEL (S):**
with curved plastic side covers
- **BUSINESS MODEL (B):**
with straight metal side covers

The recessed model is easy to integrate into the wall (F) or ceiling void (C).

APPLICATIONS

The Biddle DECO fan coil units are suitable for use in refurbished or newly built offices, meeting rooms, hotels, schools, care centres, hospitals, server rooms and retail outlets. The DECO is available in a variety of styles and designs, making it suitable for a wide range of applications.

STANDARD COLOUR COMBINATIONS

Fan coil units with casing are available in two colours. Next to the conventional white colour, the unit is available in titanium. Unless a specific colour is chosen, the unit comes standard in white. Other colours are of course available at an extra charge.

MAINTENANCE AND CLEANING

All fan coil units that have an airside or combined controller are delivered ready to use, so they are fast and easy to install. All models come standard with a removable G2 filter. This filter prevents dust in the inlet air from settling on the battery or fans.

The filter is hidden from view using a filter frame, which is easy to remove. The filter is fast and easy to clean with a vacuum cleaner.

- The filter can be withdrawn from the front of the unit.

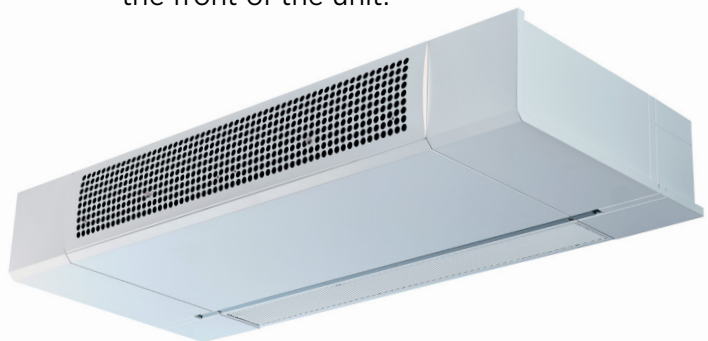

MODEL OPTIONS

The DECO is available in a wide range of different models:

TYPE CODE: DECO 75-H1C3-R-FS12

| Unit | |
|-------------------|--|
| 50 | 140 - 605 m ³ /h |
| 75 | 180 - 860 m ³ /h |
| 100 | 275 - 1180 m ³ /h |
| 125 | 300 - 1400 m ³ /h |
| 150 | 390 - 1800 m ³ /h |
| Coil type | |
| H1, H2, H4 | Water heating |
| C2, C3, C4 | Water cooling |
| H1C3 | Water heating and - cooling |
| HE | Electric heating |
| 1,2,3,4 | Number of rows |
| Water connections | |
| R | Right |
| L | Left |
| HE | Electrical connection on the left side |
| Model type | |
| FS | Floor model: stylish |
| FB | Floor model: business |
| CS | Ceiling model: stylish |
| CB | Ceiling model: business |
| FR | Recessed floor model |
| CR | Recessed ceiling model |
| 2 - 12 | See figure: model types |

MODEL TYPES:

| Figure 1. | Recirculation | Ventilation | Recirculation/Ventilation |
|---------------------------------|---------------|--------------|---------------------------|
| Free-standing | | | |
| Floor model (FS or FB) | FS2 FB2 | FB4 | FS6 FB6 |
| | | FS8 FB8 | FS10 FB10 |
| | | | FS12 FB12 |
| Free-hanging | | | |
| Ceiling model (CS or CB) | CS2 CB2 | CS6 CB6 | CS8 CB8 |
| | | CS10 CB10 | CS12 CB12 |
| Recessed | | | |
| Floor model (FR) | FR2 | FR4 | FR6 |
| | | FR8 | FR10 |
| | | | FR12 |
| Recessed | | | |
| Ceiling model (CR) | CR2 | CR4 | CR6 |
| | | CR8 | CR10 |
| | | | CR12 |

All models are available as top discharge types. Only the recessed model has the possibility of a discharge plenum for front discharge.

△ inspection side

→ air direction



STANDARD FEATURES

Units with casing come with:

- Adjustable discharge grille
- Removable air filter
- Integrated condensate draining pump (only in ceiling model with cooling mode)
- Integrated frost-protection device and damper control (only in ventilation model)
- Condensate tray (only in models with cooling mode)

Recessed units come with:

- Removable air filter
- Frost-protection device (only in ventilation model)
- Condensate tray (only in models with cooling mode)

ACCESSORIES

- Air side controller
- Air- and waterside controller
- Control panel
- CO2 sensor
- Low-voltage cables (different lengths)
- Ventilation module for coupling to an exhaust fan
- Sound - damping air inlet section
- Wall sleeve
- Wall grate
- Roof cap
- Discharge plenum for recessed models
- Flexible connection sleeves with or without duct connecting flange
- Wall and ceiling grilles
- Condensate draining pump (standard in encased ceiling model with cooling mode, optional in floor model)

Custom alterations or modifications to the unit can be made if required.

CONTROLS

Model DECO is available with three types of control, in order to make it suitable for every project.

○ BASIC (WITHOUT CONTROL)

The fan coil unit (only the recirculation model) is provided with a transformer and is wired in a fixed speed.

○ AIRSIDE CONTROL

This plug & play controller regulates the fan speed (3 speeds) to achieve the desired room temperature.

○ COMBINED AIR - AND WATERSIDE CONTROLLER

This plug & play controller regulates both the fan speed and the discharge air temperature to achieve the desired room temperature. The ventilation unit is delivered with the combined controller.



CONTROLLER WITH LCD DISPLAY

The control panel has various soft-touch keys and a clear LCD display. The desired room temperature can be set using the control panel, after which you can choose to have the controller regulate the climate either automatically or using one of the three fan speeds. Next to this functionality, the control panel features an integrated weekly timer, which can be used to switch the unit automatically on and off each day of the week. The keys of the control panel can be blocked using a key lock to prevent unwanted use.

One single control panel allows the user to interconnect and operate a maximum of ten units. The maximum length of the control cables within a control system is 100 metres. The control panel offers menus for different purposes, including operation, installation and service menus as well as a menu for setting the weekly timer.

AUTOMATIC OR MANUAL OPERATION

The control panel allows the user to select either automatic or manual operation of the DECO.

WEEKLY TIMER

The DECO comes standard with a weekly timer, which allows the user to automatically switch the unit on and off per day of the week.

CO₂ SENSOR

The ventilation units can be equipped with a sensor to read the CO₂ level in the room. The sensor ensures that the CO₂ value preset in the control panel is maintained by automatically increasing or reducing the supply of fresh air.

INTEGRATED FROST PROTECTION AND AIR VALVE CONTROL

The ventilation units have a controller-integrated frost protection thermostat and air valve control. The frost protection reduces the risk of the battery freezing (preset at 5°C). In the event of a power interruption or failure, the air valve automatically switches to the recirculation mode.

READY TO USE

Units with an airside or combined controller are delivered ready to use. The power cable (1.5m), which has a moulded-on, earthed plug, is connected to the terminal box in the side of the unit.

Via the connector plate and the interfaces in the terminal box, components such as slave units, control panel and in- and outputs can be connected to the PCB.



The control panel is inclusive room thermostat.

SPECIFICATIONS

CASING

The casing is made up of a front plate and side covers, and is available in different colours. The front plate is made of zinc plated sheeting with a hard epoxy polyester powder coating. The round sides are made of plastic, the straight sides of zinc plated sheeting. The structural parts are made of galvanised sheeting with extra strengthening to minimise distortion and vibrations. Where necessary, the models are insulated to reduce sound and heat transmission.

HEATING (LPHW) COOLING (LPCW) COILS

The high-efficiency coils are made up of 3/8" copper pipes and aluminium fins. The coils are available with 2 or 4 rows of pipes. The maximum operating pressure is 6 bar at 90°C. Then, a maximum operating pressure of 10 bar at 90°C applies. The permissible difference ($\Delta p/kP$) is as follows:

| Kvs value | 2-way valve | 3-way valve |
|-----------|-------------|-------------|
| 1 | 380 | 170 |
| 1.6 | 380 | 170 |
| 2.5 | 110 | 140 |
| 3.5 | 110 | - |
| 4 | - | 140 |

FAN / MOTOR ASSEMBLY

One or more (depending on type) dual-inlet, vibration-free suspended centrifugal fans, driven by a rotor motor on ball bearings. The fan casing and the impeller are made of zinc coated plate steel. The motor is manufactured according to DIN 40050, Protection Class IP44, and Insulation Class B. The motors have, as a standard, thermal contacts in the windings. These thermal contacts will break the circuit when the maximum permissible motor temperature is exceeded.

ELECTRIC HEATING COIL

The electric heating coil is made up of aluminium fins. The power is controlled by the electronic control unit, which is fitted with an overload protection system. When the unit is switched off, the fans will continue to rotate until the fins have cooled off sufficiently.

WEIGHTS OF VARIOUS MODELS

| Model | Type | DECO 50 | DECO 75 | DECO 100 | DECO 125 | DECO 150 |
|---|---------------------------|---------|---------|----------|----------|----------|
| With casing - stylish (type FS and CS) | Recirculation | 39 | 52 | 62 | 75 | 84 |
| | Ventilation | 41 | 55 | 65 | 79 | 88 |
| | Recirculation/Ventilation | 41 | 55 | 65 | 79 | 88 |
| With casing - business (type FB and CB) | Recirculation | 43 | 56 | 66 | 79 | 89 |
| | Ventilation | 45 | 59 | 69 | 83 | 92 |
| | Recirculation/Ventilation | 45 | 59 | 69 | 83 | 92 |
| Recessed (type FR and CR) | Recirculation | 29 | 40 | 47 | 57 | 64 |
| | Ventilation | 31 | 42 | 50 | 61 | 68 |
| | Recirculation/Ventilation | 31 | 42 | 50 | 61 | 68 |

The weights of the various fan coil models are represented in kg.

TECHNICAL DATA

DECO 50

INSTALLATION DATA

| | | |
|----------------------|---------|----------|
| Electric supply | V/ph/Hz | 230/1/50 |
| Max. running current | A | 0.35 |
| Max. consumed power | W | 90 |

GENERAL SELECTION DATA

| | Speed | 1 | 2 | 3 | 4 | 5 | 6 |
|-------------------------|-------------------|------|------|------|------|------|------|
| Tapping voltage | V | 70 | 90 | 115 | 130 | 170 | 230 |
| Power consumption, fans | A | 0.14 | 0.19 | 0.24 | 0.26 | 0.29 | 0.34 |
| Input power, fans | W | 10 | 20 | 30 | 35 | 50 | 75 |
| Air displacement | m ³ /h | 140 | 205 | 315 | 350 | 450 | 605 |
| Sound level | dB(A) | 15 | 24 | 33 | 38 | 45 | 51 |

HEATING

| | Speed | H1 LPHW 80/60°C | | | | | | H2 LPHW 80/60°C | | | | | | H4 LPHW 50/30°C | | | | | |
|---------------------|-------------------|-----------------|-----|-----|------|------|------|-----------------|-----|-----|-----|-----|------|-----------------|-----|-----|-----|-----|-----|
| | | 1 | 2 | 3 | 4 | 5 | 6 | 1 | 2 | 3 | 4 | 5 | 6 | 1 | 2 | 3 | 4 | 5 | 6 |
| Air displacement | m ³ /h | 140 | 205 | 315 | 350 | 450 | 605 | 140 | 205 | 315 | 350 | 450 | 605 | 140 | 205 | 315 | 350 | 450 | 605 |
| Air inlet temp. | °C | -10 | | | | | | -10 | | | | | | -10 | | | | | |
| Heating capacity | kW | 2.7 | 3.6 | 5 | 5.3 | 6.2 | 7.4 | 3.6 | 5 | 7 | 7.6 | 9.1 | 11.2 | 2.5 | 3.5 | 5.2 | 5.7 | 7 | 8.9 |
| Discharge temp. | °C | 42 | 37 | 32 | 31 | 27 | 23 | 59 | 54 | 49 | 48 | 44 | 39 | 37 | 36 | 34 | 33 | 31 | 29 |
| Water flow rate | l/h | 120 | 160 | 217 | 233 | 271 | 325 | 159 | 217 | 306 | 331 | 399 | 492 | 107 | 151 | 223 | 244 | 302 | 385 |
| Water pressure drop | kPa | 3.2 | 5.3 | 9.2 | 10.4 | 13.5 | 18.7 | 1.6 | 2.7 | 4.9 | 5.7 | 7.9 | 11.4 | 0.3 | 0.5 | 0.9 | 1.1 | 1.6 | 2.5 |
| Air inlet temp. | °C | 0 | | | | | | 0 | | | | | | 0 | | | | | |
| Heating capacity | kW | 2.3 | 3.1 | 4.2 | 4.5 | 5.3 | 6.3 | 3.1 | 4.2 | 5.9 | 6.4 | 7.7 | 9.5 | 1.9 | 2.7 | 3.9 | 4.3 | 5.3 | 6.7 |
| Discharge temp. | °C | 46 | 42 | 37 | 36 | 32 | 29 | 60 | 56 | 52 | 51 | 47 | 43 | 37 | 36 | 34 | 34 | 32 | 31 |
| Water flow rate | l/h | 102 | 135 | 184 | 198 | 230 | 277 | 134 | 183 | 258 | 280 | 338 | 417 | 81 | 115 | 168 | 184 | 228 | 290 |
| Water pressure loss | kPa | 2.4 | 4 | 6.9 | 7.8 | 10.1 | 14.1 | 1.2 | 2 | 3.7 | 4.2 | 5.9 | 8.5 | 0.2 | 0.3 | 0.6 | 0.7 | 1 | 1.5 |
| Air inlet temp. | °C | 10 | | | | | | 10 | | | | | | 10 | | | | | |
| Heating capacity | kW | 1.9 | 2.6 | 3.5 | 3.8 | 4.4 | 5.3 | 2.5 | 3.5 | 4.9 | 5.3 | 6.4 | 7.9 | 1.3 | 1.8 | 2.7 | 2.9 | 3.6 | 4.6 |
| Discharge temp. | °C | 49 | 46 | 42 | 41 | 38 | 35 | 61 | 58 | 54 | 53 | 51 | 47 | 37 | 36 | 34 | 34 | 33 | 32 |
| Water flow rate | l/h | 84 | 112 | 153 | 164 | 191 | 230 | 110 | 151 | 213 | 231 | 279 | 345 | 56 | 80 | 116 | 127 | 157 | 199 |
| Water pressure drop | kPa | 1.7 | 2.9 | 4.9 | 5.6 | 7.8 | 14.1 | 0.8 | 1.4 | 2.6 | 3 | 4.2 | 6.1 | 0.1 | 0.2 | 0.3 | 0.4 | 0.5 | 0.8 |
| Air inlet temp. | °C | 20 | | | | | | 20 | | | | | | 20 | | | | | |
| Heating capacity | kW | 1.5 | 2 | 2.8 | 3 | 3.5 | 4.2 | 2 | 2.8 | 3.9 | 4.2 | 5.9 | 6.3 | 0.7 | 1 | 1.5 | 1.6 | 2 | 2.5 |
| Discharge temp. | °C | 53 | 50 | 46 | 45 | 43 | 41 | 63 | 60 | 57 | 56 | 54 | 51 | 35 | 35 | 34 | 34 | 33 | 32 |
| Water flow rate | l/h | 67 | 90 | 122 | 132 | 153 | 185 | 88 | 121 | 170 | 185 | 223 | 276 | 31 | 44 | 63 | 69 | 85 | 106 |
| Water pressure drop | kPa | 1.2 | 1.9 | 3.3 | 3.8 | 5 | 6.9 | 0.6 | 1 | 1.8 | 2 | 2.8 | 4.1 | 0 | 0.1 | 0.1 | 0.1 | 0.2 | 0.3 |

COOLING

| | Speed | C2 LPCW 6/12°C | | | | | | C3 LPCW 6/12°C | | | | | | C4 LPCW 6/12°C | | | | | |
|------------------------|-------------------|----------------|-----|-----|-----|-----|-----|----------------|-----|-----|-----|-----|-----|----------------|-----|-----|-----|-----|-----|
| | | 1 | 2 | 3 | 4 | 5 | 6 | 1 | 2 | 3 | 4 | 5 | 6 | 1 | 2 | 3 | 4 | 5 | 6 |
| Air displacement | m ³ /h | 140 | 205 | 315 | 350 | 450 | 605 | 140 | 205 | 315 | 350 | 450 | 605 | 140 | 205 | 315 | 350 | 450 | 605 |
| Air inlet temp. | °C | 27 | | | | | | 27 | | | | | | 27 | | | | | |
| Relative humidity | % | 48 | | | | | | 48 | | | | | | 48 | | | | | |
| Cooling capacity total | kW | 0.9 | 1.2 | 1.6 | 1.7 | 2 | 2.4 | 1 | 1.4 | 1.9 | 2 | 2.5 | 3 | 1 | 1.5 | 2.1 | 2.3 | 2.8 | 3.5 |
| Sensible capacity | kW | 0.7 | 0.9 | 1.3 | 1.4 | 1.7 | 2.1 | 0.7 | 1 | 1.5 | 1.6 | 2 | 2.5 | 0.8 | 1 | 1.6 | 1.7 | 2.1 | 2.8 |
| Discharge temp. | °C | 13 | 14 | 15 | 15 | 16 | 17 | 11 | 12 | 13 | 13 | 14 | 14 | 11 | 11 | 12 | 12 | 13 | 13 |
| Water flow rate | l/h | 124 | 167 | 226 | 243 | 285 | 341 | 142 | 195 | 273 | 296 | 355 | 434 | 151 | 211 | 302 | 329 | 400 | 498 |
| Water pressure drop | kPa | 1.4 | 2.3 | 3.9 | 4.5 | 5.6 | 8.1 | 0.9 | 1.5 | 2.7 | 3.1 | 4.3 | 6 | 0.6 | 1 | 1.9 | 2.3 | 3.2 | 4.7 |

* The control system limits the air discharge temperature to 50°C. This limitation is not included in the selection data.

** Water pressure loss, exclusive three- or two-way valve. For sft-values of three- or two-way valve, see page 22.

TECHNICAL DATA

DECO 75

INSTALLATION DATA

| | | |
|----------------------|---------|----------|
| Electric supply | V/ph/Hz | 230/1/50 |
| Max. running current | A | 0.82 |
| Max. consumed power | W | 180 |

GENERAL SELECTION DATA

| | Speed | 1 | 2 | 3 | 4 | 5 | 6 |
|-------------------------|-------------------|------|------|------|------|------|------|
| Tapping voltage | V | 60 | 80 | 100 | 115 | 155 | 230 |
| Power consumption, fans | A | 0.29 | 0.37 | 0.44 | 0.49 | 0.54 | 0.62 |
| Input power, fans | W | 20 | 30 | 45 | 55 | 80 | 140 |
| Air displacement | m ³ /h | 180 | 275 | 420 | 515 | 680 | 860 |
| Sound level | dB(A) | 14 | 26 | 34 | 39 | 46 | 51 |

HEATING

| | Speed | H1 LPHW 80/60°C | | | | | | H2 LPHW 80/60°C | | | | | | H4 LPHW 50/30°C | | | | | |
|---------------------|-------------------|-----------------|-----|------|------|------|------|-----------------|-----|------|------|------|------|-----------------|-----|-----|-----|------|------|
| | | 1 | 2 | 3 | 4 | 5 | 6 | 1 | 2 | 3 | 4 | 5 | 6 | 1 | 2 | 3 | 4 | 5 | 6 |
| Air displacement | m ³ /h | 180 | 275 | 420 | 515 | 680 | 860 | 180 | 275 | 420 | 515 | 680 | 860 | 180 | 275 | 420 | 515 | 680 | 860 |
| Air inlet temp. | °C | -10 | | | | | | -10 | | | | | | -10 | | | | | |
| Heating capacity | kW | 3.7 | 5.1 | 7 | 8.1 | 9.5 | 11 | 4.8 | 6.9 | 9.7 | 11.4 | 14 | 16.6 | 3.2 | 4.8 | 7.1 | 8.6 | 10.9 | 13.2 |
| Discharge temp. | °C | 45 | 40 | 34 | 32 | 27 | 24 | 61 | 57 | 52 | 49 | 45 | 41 | 38 | 37 | 35 | 34 | 33 | 31 |
| Water flow rate | l/h | 163 | 225 | 307 | 353 | 418 | 484 | 210 | 304 | 426 | 499 | 615 | 727 | 140 | 209 | 308 | 369 | 470 | 572 |
| Water pressure drop | kPa | 7.4 | 13 | 22.4 | 28.7 | 38.5 | 49.9 | 3.4 | 6.5 | 11.8 | 15.6 | 22.5 | 30.1 | 0.6 | 1.1 | 2.2 | 3.1 | 4.7 | 6.6 |
| Air inlet temp. | °C | 0 | | | | | | 0 | | | | | | 0 | | | | | |
| Heating capacity | kW | 3.2 | 4.4 | 6 | 6.9 | 8.1 | 9.4 | 4.1 | 5.9 | 8.2 | 9.7 | 11.9 | 14.1 | 2.5 | 3.7 | 5.4 | 6.5 | 8.3 | 10 |
| Discharge temp. | °C | 49 | 44 | 39 | 37 | 33 | 30 | 62 | 59 | 54 | 52 | 48 | 45 | 38 | 37 | 36 | 35 | 34 | 32 |
| Water flow rate | l/h | 138 | 191 | 261 | 301 | 356 | 413 | 177 | 257 | 361 | 423 | 522 | 617 | 106 | 159 | 234 | 280 | 357 | 434 |
| Water pressure loss | kPa | 5.5 | 9.7 | 16.8 | 21.6 | 29.1 | 37.8 | 2.5 | 4.8 | 8.8 | 11.6 | 16.8 | 22.6 | 0.4 | 0.7 | 1.4 | 1.9 | 2.9 | 4.1 |
| Air inlet temp. | °C | 10 | | | | | | 10 | | | | | | 10 | | | | | |
| Heating capacity | kW | 2.6 | 3.6 | 4.9 | 5.7 | 6.8 | 7.9 | 3.3 | 4.8 | 6.8 | 8 | 9.9 | 11.7 | 1.7 | 2.6 | 3.8 | 4.5 | 5.8 | 7 |
| Discharge temp. | °C | 52 | 48 | 44 | 42 | 39 | 36 | 63 | 60 | 56 | 54 | 52 | 49 | 38 | 37 | 36 | 35 | 34 | 33 |
| Water flow rate | l/h | 125 | 159 | 217 | 250 | 297 | 344 | 146 | 212 | 298 | 350 | 432 | 512 | 75 | 112 | 164 | 196 | 249 | 302 |
| Water pressure drop | kPa | 4 | 7 | 12.1 | 15.6 | 21.1 | 27.4 | 1.8 | 3.5 | 6.3 | 8.3 | 12.1 | 16.3 | 0.2 | 0.4 | 0.7 | 1 | 1.5 | 2.1 |
| Air inlet temp. | °C | 20 | | | | | | 20 | | | | | | 20 | | | | | |
| Heating capacity | kW | 2.1 | 2.9 | 4 | 4.6 | 5.5 | 6.3 | 2.7 | 3.9 | 5.5 | 6.4 | 7.9 | 9.4 | 1 | 1.5 | 2.1 | 2.5 | 3.2 | 3.9 |
| Discharge temp. | °C | 55 | 51 | 48 | 46 | 44 | 42 | 64 | 62 | 59 | 57 | 55 | 52 | 36 | 36 | 35 | 35 | 34 | 33 |
| Water flow rate | l/h | 92 | 127 | 174 | 201 | 230 | 278 | 117 | 170 | 239 | 281 | 347 | 412 | 43 | 63 | 92 | 109 | 138 | 167 |
| Water pressure drop | kPa | 2.7 | 4.8 | 8.3 | 10.7 | 14.4 | 18.8 | 1.2 | 2.3 | 4.3 | 5.7 | 8.2 | 11.1 | 0.1 | 0.1 | 0.3 | 0.4 | 0.5 | 0.8 |

COOLING

| | Speed | C2 LPCW 6/12°C | | | | | | C3 LPCW 6/12°C | | | | | | C4 LPCW 6/12°C | | | | | |
|------------------------|-------------------|----------------|-----|------|------|------|-----|----------------|-----|-----|-----|------|------|----------------|-----|-----|-----|-----|------|
| | | 1 | 2 | 3 | 4 | 5 | 6 | 1 | 2 | 3 | 4 | 5 | 6 | 1 | 2 | 3 | 4 | 5 | 6 |
| Air displacement | m ³ /h | 180 | 275 | 420 | 515 | 680 | 860 | 180 | 275 | 420 | 515 | 680 | 860 | 180 | 275 | 420 | 515 | 680 | 860 |
| Air inlet temp. | °C | 27 | | | | | | 27 | | | | | | 27 | | | | | |
| Relative humidity | % | 48 | | | | | | 48 | | | | | | 48 | | | | | |
| Cooling capacity total | kW | 1.2 | 1.7 | 2.4 | 2.7 | 3.3 | 3.8 | 1.4 | 2 | 2.8 | 3.3 | 4 | 4.8 | 1.4 | 2.1 | 3 | 3.6 | 4.6 | 5.5 |
| Sensible capacity | kW | 0.9 | 1.3 | 1.8 | 2.1 | 2.7 | 3.2 | 1 | 1.4 | 2 | 2.5 | 3.1 | 3.8 | 1 | 1.5 | 2.2 | 2.6 | 3.4 | 4.1 |
| Discharge temp. | °C | 12 | 13 | 14 | 14 | 15 | 16 | 11 | 11 | 12 | 12 | 13 | 14 | 10 | 11 | 11 | 11 | 12 | 12 |
| Water flow rate | l/h | 176 | 247 | 340 | 393 | 474 | 549 | 196 | 283 | 402 | 472 | 582 | 688 | 205 | 302 | 438 | 520 | 652 | 781 |
| Water pressure drop | kPa | 3.4 | 6.2 | 10.8 | 13.9 | 19.3 | 25 | 2 | 3.8 | 7 | 9.4 | 13.6 | 18.2 | 1.3 | 2.6 | 5 | 6.7 | 10 | 13.7 |

* The control system limits the air discharge temperature to 50°C. This limitation is not included in the selection data.

** Water pressure loss, exclusive three- or two-way valve. For sft-values of three- or two-way valve, see page 22.

TECHNICAL DATA

DECO 100

INSTALLATION DATA

| | | |
|----------------------|---------|----------|
| Electric supply | V/ph/Hz | 230/1/50 |
| Max. running current | A | 0.82 |
| Max. consumed power | W | 180 |

GENERAL SELECTION DATA

| | Speed | 1 | 2 | 3 | 4 | 5 | 6 |
|-------------------------|-------------------|------|------|------|------|------|------|
| Tapping voltage | V | 70 | 90 | 115 | 130 | 170 | 230 |
| Power consumption, fans | A | 0.33 | 0.41 | 0.51 | 0.56 | 0.63 | 0.69 |
| Input power, fans | W | 25 | 40 | 60 | 70 | 105 | 155 |
| Air displacement | m ³ /h | 275 | 405 | 635 | 700 | 900 | 1180 |
| Sound level | dB(A) | 15 | 24 | 34 | 38 | 46 | 51 |

HEATING

| | Speed | H1 LPHW 80/60°C | | | | | | H2 LPHW 80/60°C | | | | | | H4 LPHW 50/30°C | | | | | |
|---------------------|-------------------|-----------------|-----|-----|------|------|------|-----------------|-----|------|------|------|------|-----------------|-----|------|------|------|------|
| | | 1 | 2 | 3 | 4 | 5 | 6 | 1 | 2 | 3 | 4 | 5 | 6 | 1 | 2 | 3 | 4 | 5 | 6 |
| Air displacement | m ³ /h | 275 | 405 | 635 | 700 | 900 | 1180 | 275 | 405 | 635 | 700 | 900 | 1180 | 275 | 405 | 635 | 700 | 900 | 1180 |
| Air inlet temp. | °C | -10 | | | | | | -10 | | | | | | -10 | | | | | |
| Heating capacity | kW | 5.4 | 7.2 | 10 | 10.6 | 12.3 | 14.6 | 7.1 | 9.8 | 14 | 15.1 | 18.2 | 22.1 | 4.9 | 6.9 | 10.4 | 11.3 | 14 | 17.5 |
| Discharge temp. | °C | 42 | 38 | 32 | 31 | 27 | 23 | 59 | 55 | 49 | 48 | 44 | 40 | 37 | 36 | 34 | 33 | 31 | 29 |
| Water flow rate | l/h | 237 | 317 | 437 | 466 | 541 | 641 | 312 | 430 | 615 | 663 | 799 | 967 | 210 | 300 | 448 | 488 | 605 | 755 |
| Water pressure drop | kPa | 2.5 | 4.2 | 7.4 | 8.4 | 10.9 | 14.6 | 1.2 | 2.1 | 4 | 4.6 | 6.4 | 8.9 | 0.2 | 0.4 | 0.8 | 0.9 | 1.3 | 1.9 |
| Air inlet temp. | °C | 0 | | | | | | 0 | | | | | | 0 | | | | | |
| Heating capacity | kW | 4.6 | 6.1 | 8.5 | 9 | 10.5 | 12.4 | 6 | 8.3 | 11.9 | 12.8 | 15.4 | 18.7 | 3.7 | 5.3 | 7.8 | 8.5 | 10.5 | 13.2 |
| Discharge temp. | °C | 46 | 42 | 37 | 36 | 32 | 29 | 60 | 57 | 52 | 51 | 47 | 44 | 37 | 36 | 34 | 34 | 32 | 31 |
| Water flow rate | l/h | 201 | 268 | 371 | 396 | 460 | 545 | 263 | 363 | 520 | 560 | 676 | 819 | 159 | 227 | 338 | 368 | 456 | 568 |
| Water pressure loss | kPa | 1.9 | 3.2 | 5.6 | 6.3 | 8.2 | 11 | 0.9 | 1.6 | 3 | 3.4 | 4.7 | 6.6 | 0.1 | 0.2 | 0.5 | 0.5 | 0.8 | 1.2 |
| Air inlet temp. | °C | 10 | | | | | | 10 | | | | | | 10 | | | | | |
| Heating capacity | kW | 3.8 | 5.1 | 7 | 7.5 | 8.7 | 10.3 | 4.9 | 6.8 | 9.8 | 10.6 | 12.7 | 15.5 | 2.6 | 3.7 | 5.4 | 5.9 | 7.3 | 9 |
| Discharge temp. | °C | 49 | 46 | 42 | 41 | 38 | 35 | 62 | 58 | 54 | 53 | 51 | 48 | 37 | 36 | 34 | 34 | 33 | 32 |
| Water flow rate | l/h | 166 | 222 | 307 | 328 | 382 | 453 | 217 | 299 | 429 | 463 | 559 | 678 | 111 | 158 | 234 | 254 | 314 | 390 |
| Water pressure drop | kPa | 1.4 | 2.3 | 4 | 4.5 | 5.9 | 7.9 | 0.6 | 1.1 | 2.1 | 2.4 | 3.4 | 4.8 | 0.1 | 0.1 | 0.2 | 0.3 | 0.4 | 0.6 |
| Air inlet temp. | °C | 20 | | | | | | 20 | | | | | | 20 | | | | | |
| Heating capacity | kW | 3 | 4.1 | 5.6 | 6 | 7 | 8.3 | 4 | 5.5 | 7.8 | 8.4 | 10.2 | 12.4 | 1.4 | 2 | 3 | 3.2 | 3.9 | 4.8 |
| Air outlet temp. | °C | 53 | 50 | 46 | 45 | 43 | 41 | 63 | 60 | 57 | 56 | 54 | 51 | 35 | 35 | 34 | 34 | 33 | 32 |
| Water flow rate | l/h | 133 | 178 | 246 | 263 | 306 | 363 | 173 | 241 | 343 | 370 | 447 | 542 | 62 | 87 | 127 | 138 | 169 | 209 |
| Water pressure drop | kPa | 0.9 | 1.5 | 2.7 | 3.1 | 4 | 5.4 | 0.4 | 0.8 | 1.4 | 1.6 | 2.3 | 3.2 | 0 | 0 | 0.1 | 0.1 | 0.1 | 0.2 |

COOLING

| | Speed | C2 LPCW 6/12°C | | | | | | C3 LPCW 6/12°C | | | | | | C4 LPCW 6/12°C | | | | | |
|------------------------|-------------------|----------------|-----|-----|-----|-----|------|----------------|-----|-----|-----|-----|------|----------------|-----|-----|-----|-----|------|
| | | 1 | 2 | 3 | 4 | 5 | 6 | 1 | 2 | 3 | 4 | 5 | 6 | 1 | 2 | 3 | 4 | 5 | 6 |
| Air displacement | m ³ /h | 275 | 405 | 635 | 700 | 900 | 1180 | 275 | 405 | 635 | 700 | 900 | 1180 | 275 | 405 | 635 | 700 | 900 | 1180 |
| Air inlet temp. | °C | 27 | | | | | | 27 | | | | | | 27 | | | | | |
| Relative humidity | % | 48 | | | | | | 48 | | | | | | 48 | | | | | |
| Cooling capacity total | kW | 1.7 | 2.3 | 3.2 | 3.4 | 4 | 4.7 | 2 | 2.7 | 3.8 | 4.1 | 5 | 6 | 2.1 | 2.9 | 4.3 | 4.6 | 5.6 | 6.8 |
| Sensible capacity | kW | 1.3 | 1.8 | 2.6 | 2.8 | 3.4 | 4.1 | 1.4 | 2 | 3 | 3.2 | 4 | 4.9 | 1.5 | 2.1 | 3.2 | 3.5 | 4.3 | 5.4 |
| Discharge temp. | °C | 13 | 14 | 15 | 15 | 16 | 16 | 11 | 12 | 13 | 13 | 14 | 14 | 11 | 11 | 12 | 12 | 13 | 13 |
| Water flow rate | l/h | 245 | 330 | 455 | 485 | 571 | 672 | 279 | 386 | 549 | 591 | 709 | 853 | 297 | 417 | 608 | 658 | 801 | 979 |
| Water pressure drop | kPa | 1.1 | 1.8 | 3.2 | 3.6 | 4.8 | 6.4 | 0.7 | 1.2 | 2.2 | 2.5 | 3.4 | 4.8 | 0.5 | 0.8 | 1.6 | 1.8 | 2.6 | 3.6 |

* The control system limits the air discharge temperature to 50°C. This limitation is not included in the selection data.

** Water pressure loss, exclusive three- or two- way valve. For sft-values of three- or two-way valve, see page 22.

TECHNICAL DATA

DECO 125

INSTALLATION DATA

| | | |
|----------------------|---------|----------|
| Electric supply | V/ph/Hz | 230/1/50 |
| Max. running current | A | 1.2 |
| Max. consumed power | W | 270 |

GENERAL SELECTION DATA

| | Speed | 1 | 2 | 3 | 4 | 5 | 6 |
|-------------------------|-------------------|------|------|------|------|------|------|
| Tapping voltage | V | 60 | 80 | 100 | 115 | 155 | 230 |
| Power consumption, fans | A | 0.42 | 0.57 | 0.68 | 0.77 | 0.86 | 0.97 |
| Input power, fans | W | 25 | 45 | 65 | 85 | 125 | 215 |
| Air displacement | m ³ /h | 300 | 440 | 660 | 840 | 1070 | 1400 |
| Sound level | dB(A) | 14 | 23 | 32 | 37 | 45 | 51 |

HEATING

| | Speed | H1 LPHW 80/60°C | | | | | | H2 LPHW 80/60°C | | | | | | H4 LPHW 50/30°C | | | | | |
|---------------------|-------------------|-----------------|-----|------|------|------|------|-----------------|------|------|------|------|------|-----------------|-----|------|------|------|------|
| | | 1 | 2 | 3 | 4 | 5 | 6 | 1 | 2 | 3 | 4 | 5 | 6 | 1 | 2 | 3 | 4 | 5 | 6 |
| Air displacement | m ³ /h | 300 | 440 | 660 | 840 | 1070 | 1400 | 300 | 440 | 660 | 840 | 1070 | 1400 | 300 | 440 | 660 | 840 | 1070 | 1400 |
| Air inlet temp. | °C | -10 | | | | | | -10 | | | | | | -10 | | | | | |
| Heating capacity | kW | 6.2 | 8.2 | 11.1 | 13.1 | 15.2 | 18 | 8 | 11.1 | 15.4 | 18.5 | 22.2 | 26.9 | 5.4 | 7.7 | 11.2 | 13.8 | 17.1 | 21.4 |
| Discharge temp. | °C | 45 | 40 | 35 | 32 | 28 | 24 | 61 | 57 | 52 | 49 | 45 | 41 | 38 | 37 | 35 | 34 | 33 | 31 |
| Water flow rate | l/h | 270 | 361 | 486 | 575 | 664 | 787 | 349 | 487 | 673 | 812 | 975 | 1181 | 232 | 334 | 482 | 598 | 737 | 923 |
| Water pressure drop | kPa | 3.8 | 6.4 | 10.8 | 14.5 | 18.7 | 25.3 | 1.8 | 3.2 | 5.7 | 7.9 | 10.9 | 15.2 | 0.3 | 0.5 | 1.1 | 1.5 | 2.2 | 3.3 |
| Air inlet temp. | °C | 0 | | | | | | 0 | | | | | | 0 | | | | | |
| Heating capacity | kW | 5.2 | 7 | 9.4 | 11.2 | 12.9 | 15.3 | 6.7 | 9.4 | 13 | 15.7 | 18.8 | 22.9 | 4.1 | 5.9 | 8.5 | 10.5 | 12.9 | 16.1 |
| Discharge temp. | °C | 48 | 44 | 39 | 37 | 33 | 30 | 62 | 59 | 54 | 52 | 49 | 45 | 38 | 37 | 35 | 34 | 33 | 32 |
| Water flow rate | l/h | 229 | 306 | 413 | 489 | 566 | 671 | 294 | 411 | 569 | 687 | 825 | 1002 | 176 | 253 | 366 | 453 | 558 | 698 |
| Water pressure loss | kPa | 2.9 | 4.8 | 8.1 | 10.9 | 14.1 | 19.1 | 1.3 | 2.4 | 4.2 | 5.9 | 8.1 | 11.4 | 0.2 | 0.3 | 0.6 | 0.9 | 1.4 | 2 |
| Air inlet temp. | °C | 10 | | | | | | 10 | | | | | | 10 | | | | | |
| Heating capacity | kW | 4.3 | 5.8 | 7.8 | 9.3 | 10.7 | 12.7 | 5.5 | 7.7 | 10.7 | 13 | 15.6 | 18.9 | 2.9 | 4.1 | 5.9 | 7.3 | 9 | 11.2 |
| Discharge temp. | °C | 51 | 48 | 44 | 42 | 39 | 36 | 63 | 60 | 57 | 54 | 52 | 49 | 37 | 37 | 36 | 35 | 34 | 33 |
| Water flow rate | l/h | 189 | 254 | 342 | 406 | 470 | 558 | 242 | 339 | 470 | 569 | 683 | 830 | 12 | 177 | 255 | 315 | 388 | 484 |
| Water pressure drop | kPa | 2.1 | 3.4 | 5.8 | 7.9 | 10.2 | 13.8 | 0.9 | 1.7 | 3 | 4.2 | 5.8 | 8.2 | 0.1 | 0.2 | 0.3 | 0.5 | 0.7 | 1.2 |
| Air inlet temp. | °C | 20 | | | | | | 20 | | | | | | 20 | | | | | |
| Heating capacity | kW | 3.5 | 4.6 | 6.3 | 7.5 | 8.6 | 10.3 | 4.4 | 6.2 | 8.6 | 10.4 | 12.5 | 15.2 | 1.6 | 2.3 | 3.3 | 4 | 4.9 | 6.1 |
| Discharge temp. | °C | 54 | 51 | 48 | 46 | 44 | 42 | 64 | 62 | 59 | 57 | 55 | 52 | 36 | 36 | 35 | 34 | 34 | 33 |
| Water flow rate | l/h | 152 | 204 | 275 | 326 | 378 | 449 | 194 | 271 | 376 | 455 | 548 | 666 | 70 | 100 | 142 | 174 | 213 | 264 |
| Water pressure drop | kPa | 1.4 | 2.3 | 4 | 5.4 | 7 | 9.4 | 0.6 | 1.1 | 2 | 2.8 | 3.9 | 5.6 | 0 | 0.1 | 0.1 | 0.2 | 0.2 | 0.4 |

COOLING

| | Speed | C2 LPCW 6/12°C | | | | | | C3 LPCW 6/12°C | | | | | | C4 LPCW 6/12°C | | | | | |
|------------------------|-------------------|----------------|-----|-----|-----|------|------|----------------|-----|-----|-----|------|------|----------------|-----|-----|-----|------|------|
| | | 1 | 2 | 3 | 4 | 5 | 6 | 1 | 2 | 3 | 4 | 5 | 6 | 1 | 2 | 3 | 4 | 5 | 6 |
| Air displacement | m ³ /h | 300 | 440 | 660 | 840 | 1070 | 1400 | 300 | 440 | 660 | 840 | 1070 | 1400 | 300 | 440 | 660 | 840 | 1070 | 1400 |
| Air inlet temp. | °C | 27 | | | | | | 27 | | | | | | 27 | | | | | |
| Relative humidity | % | 48 | | | | | | 48 | | | | | | 48 | | | | | |
| Cooling capacity total | kW | 2 | 2.7 | 3.7 | 4.4 | 5.1 | 6.1 | 2.2 | 3.1 | 4.3 | 5.2 | 6.3 | 7.6 | 2.4 | 3.3 | 4.7 | 5.8 | 7 | 8.6 |
| Sensible capacity | kW | 1.5 | 2 | 2.9 | 3.5 | 4.2 | 5.1 | 1.6 | 2.3 | 3.2 | 4 | 4.9 | 6.1 | 1.7 | 2.7 | 3.4 | 4.3 | 5.3 | 6.6 |
| Discharge temp. | °C | 12 | 13 | 14 | 15 | 15 | 16 | 11 | 11 | 12 | 13 | 13 | 14 | 10 | 11 | 11 | 12 | 12 | 13 |
| Water flow rate | l/h | 286 | 388 | 525 | 623 | 732 | 866 | 320 | 445 | 622 | 751 | 900 | 1088 | 337 | 476 | 678 | 829 | 1007 | 1238 |
| Water pressure drop | kPa | 1.7 | 2.9 | 5 | 6.7 | 8.9 | 12 | 1 | 1.8 | 3.3 | 4.6 | 6.3 | 8.8 | 0.7 | 1.2 | 2.3 | 3.3 | 4.6 | 6.6 |

* The control system limits the air discharge temperature to 50°C. This limitation is not included in the selection data.

** Water pressure loss, exclusive three- or two- way valve. For sft-values of three- or two-way valve, see page 22.

TECHNICAL DATA

DECO 150

INSTALLATION DATA

| | | |
|----------------------|---------|----------|
| Electric supply | V/ph/Hz | 230/1/50 |
| Max. running current | A | 1.2 |
| Max. consumed power | W | 270 |

GENERAL SELECTION DATA

| | Speed | 1 | 2 | 3 | 4 | 5 | 6 |
|-------------------------|-------------------|-----|------|------|------|------|------|
| Tapping voltage | V | 70 | 90 | 115 | 130 | 170 | 230 |
| Power consumption, fans | A | 0.5 | 0.62 | 0.77 | 0.84 | 0.94 | 1.03 |
| Input power, fans | W | 35 | 55 | 85 | 105 | 155 | 230 |
| Air displacement | m ³ /h | 390 | 610 | 880 | 1050 | 1350 | 1800 |
| Sound level | dB(A) | 15 | 24 | 34 | 38 | 46 | 51 |

HEATING

| | Speed | H1 LPHW 80/60°C | | | | | | H2 LPHW 80/60°C | | | | | | H4 LPHW 50/30°C | | | | | |
|---------------------|-------------------|-----------------|------|------|------|------|------|-----------------|------|------|------|------|------|-----------------|------|------|------|------|------|
| | | 1 | 2 | 3 | 4 | 5 | 6 | 1 | 2 | 3 | 4 | 5 | 6 | 1 | 2 | 3 | 4 | 5 | 6 |
| Air displacement | m ³ /h | 390 | 610 | 880 | 1050 | 1350 | 1800 | 390 | 610 | 880 | 1050 | 1350 | 1800 | 390 | 610 | 880 | 1050 | 1350 | 1800 |
| Air inlet temp. | °C | -10 | | | | | | -10 | | | | | | -10 | | | | | |
| Heating capacity | kW | 7.9 | 11.1 | 14.5 | 16.3 | 19 | 22.7 | 10.3 | 15 | 20.2 | 23.1 | 27.9 | 34.2 | 7 | 10.6 | 14.9 | 17.4 | 21.6 | 27.5 |
| Discharge temp. | °C | 44 | 38 | 34 | 31 | 27 | 24 | 60 | 56 | 51 | 49 | 45 | 41 | 38 | 36 | 35 | 34 | 33 | 31 |
| Water flow rate | l/h | 347 | 486 | 634 | 716 | 831 | 996 | 452 | 658 | 884 | 1014 | 1223 | 1500 | 302 | 460 | 642 | 751 | 934 | 1188 |
| Water pressure drop | kPa | 7 | 12.7 | 20.2 | 25 | 32.5 | 44.7 | 3.3 | 6.4 | 10.7 | 13.6 | 19 | 27.1 | 0.5 | 1.1 | 2 | 2.7 | 3.9 | 6 |
| Air inlet temp. | °C | 0 | | | | | | 0 | | | | | | 0 | | | | | |
| Heating capacity | kW | 6.7 | 9.4 | 12.3 | 13.9 | 16.2 | 19.4 | 8.7 | 12.7 | 17.1 | 19.6 | 23.7 | 29.1 | 5.3 | 8.1 | 11.3 | 13.2 | 16.4 | 20.8 |
| Discharge temp. | °C | 48 | 43 | 39 | 37 | 33 | 30 | 62 | 58 | 54 | 52 | 49 | 45 | 38 | 37 | 35 | 35 | 34 | 32 |
| Water flow rate | l/h | 294 | 413 | 539 | 610 | 709 | 850 | 381 | 556 | 748 | 859 | 1037 | 1274 | 230 | 349 | 488 | 570 | 709 | 900 |
| Water pressure loss | kPa | 5.2 | 9.5 | 15.2 | 18.8 | 24.6 | 33.8 | 2.4 | 4.7 | 8 | 10.2 | 14.2 | 20.4 | 0.3 | 0.7 | 1.3 | 1.7 | 2.4 | 3.7 |
| Air inlet temp. | °C | 10 | | | | | | 10 | | | | | | 10 | | | | | |
| Heating capacity | kW | 5.6 | 7.8 | 10.2 | 11.6 | 13.5 | 16.2 | 7.2 | 10.5 | 14.1 | 16.2 | 19.6 | 24.1 | 3.8 | 5.7 | 7.9 | 9.2 | 11.4 | 14.5 |
| Discharge temp. | °C | 51 | 47 | 43 | 42 | 39 | 36 | 63 | 59 | 56 | 54 | 52 | 48 | 38 | 37 | 36 | 35 | 34 | 33 |
| Water flow rate | l/h | 244 | 343 | 448 | 507 | 590 | 709 | 314 | 460 | 619 | 711 | 860 | 1058 | 162 | 246 | 341 | 399 | 495 | 627 |
| Water pressure drop | kPa | 3.8 | 6.8 | 11 | 13.6 | 17.8 | 24.6 | 1.7 | 3.4 | 5.7 | 7.3 | 10.2 | 14.7 | 0.2 | 0.4 | 0.7 | 0.9 | 1.3 | 2 |
| Air inlet temp. | °C | 20 | | | | | | 20 | | | | | | 20 | | | | | |
| Heating capacity | kW | 4.5 | 6.3 | 8.2 | 9.3 | 10.9 | 13 | 5.7 | 8.5 | 11.3 | 13 | 15.8 | 19.4 | 2.1 | 3.2 | 4.4 | 5.2 | 6.4 | 8 |
| Discharge temp. | °C | 54 | 51 | 48 | 46 | 44 | 41 | 64 | 61 | 58 | 57 | 55 | 52 | 36 | 36 | 35 | 35 | 34 | 33 |
| Water flow rate | l/h | 196 | 275 | 361 | 408 | 476 | 572 | 252 | 371 | 497 | 570 | 690 | 850 | 92 | 139 | 191 | 223 | 275 | 347 |
| Water pressure drop | kPa | 2.6 | 4.7 | 7.5 | 9.3 | 12.2 | 16.8 | 1.2 | 2.3 | 3.9 | 4.9 | 6.9 | 10 | 0.1 | 0.1 | 0.2 | 0.3 | 0.5 | 0.7 |

COOLING

| | Speed | C2 LPCW 6/12°C | | | | | | C3 LPCW 6/12°C | | | | | | C4 LPCW 6/12°C | | | | | |
|------------------------|-------------------|----------------|-----|-----|------|------|------|----------------|-----|-----|------|------|------|----------------|-----|-----|------|------|------|
| | | 1 | 2 | 3 | 4 | 5 | 6 | 1 | 2 | 3 | 4 | 5 | 6 | 1 | 2 | 3 | 4 | 5 | 6 |
| Air displacement | m ³ /h | 390 | 610 | 880 | 1050 | 1350 | 1800 | 390 | 610 | 880 | 1050 | 1350 | 1800 | 390 | 610 | 880 | 1050 | 1350 | 1800 |
| Air inlet temp. | °C | 27 | | | | | | 27 | | | | | | 27 | | | | | |
| Relative humidity | % | 48 | | | | | | 48 | | | | | | 48 | | | | | |
| Cooling capacity total | kW | 2.6 | 3.7 | 4.9 | 5.6 | 6.6 | 7.9 | 2.9 | 4.3 | 5.8 | 6.7 | 8.1 | 9.9 | 3.1 | 4.6 | 6.4 | 7.4 | 9 | 11.3 |
| Sensible capacity | kW | 1.9 | 2.8 | 3.8 | 4.4 | 5.3 | 6.6 | 2.1 | 3.1 | 4.3 | 5 | 6.2 | 7.8 | 2.2 | 3.3 | 4.6 | 5.4 | 6.7 | 8.6 |
| Discharge temp. | °C | 12 | 13 | 14 | 14 | 15 | 16 | 11 | 11 | 12 | 13 | 13 | 14 | 10 | 11 | 11 | 11 | 12 | 13 |
| Water flow rate | l/h | 376 | 536 | 704 | 797 | 943 | 1129 | 420 | 618 | 835 | 959 | 1159 | 1421 | 442 | 662 | 911 | 1057 | 1295 | 1617 |
| Water pressure drop | kPa | 3.2 | 6 | 9.7 | 12 | 16 | 22.3 | 1.9 | 3.8 | 6.4 | 8.2 | 11.4 | 16.4 | 1.3 | 2.6 | 4.5 | 5.9 | 8.4 | 12.4 |

* The control system limits the air discharge temperature to 50°C. This limitation is not included in the selection data.

** Water pressure loss, exclusive three- or two- way valve. For sft-values of three- or two-way valve, see page 22.

TECHNICAL DATA

DECO HE

INSTALLATION DATA

| | | DECO 50 | DECO 100 | DECO 150 |
|------------------------------|---------|-----------|-----------|-----------|
| Electric supply | V/ph/Hz | 400/3N/50 | 400/3N/50 | 400/3N/50 |
| Max. running current | A | 10.4 | 16 | 23.8 |
| Max. consumed power heating* | kW | 7.1 | 10.7 | 15.9 |

* With electric heating, the heating capacity is 5% lower than the installed power.

GENERAL SELECTION DATA

| | | DECO 50 | | | | | | DECO 100 | | | | | | DECO 150 | | | | | | |
|-------------------------|-------------------|---------|------|------|------|------|------|----------|------|------|------|------|------|----------|------|------|------|------|------|---|
| | | Speed | 1 | 2 | 3 | 4 | 5 | 6 | 1 | 2 | 3 | 4 | 5 | 6 | 1 | 2 | 3 | 4 | 5 | 6 |
| Tapping voltage | V | 70 | 90 | 115 | 130 | 170 | 230 | 70 | 90 | 115 | 130 | 170 | 230 | 70 | 90 | 115 | 130 | 170 | 230 | |
| Power consumption, fans | A | 0.14 | 0.19 | 0.24 | 0.26 | 0.29 | 0.34 | 0.33 | 0.41 | 0.51 | 0.56 | 0.63 | 0.69 | 0.5 | 0.62 | 0.77 | 0.84 | 0.94 | 1.03 | |
| Input power, fans | W | 10 | 20 | 30 | 35 | 50 | 75 | 25 | 40 | 60 | 70 | 105 | 155 | 35 | 55 | 85 | 105 | 155 | 230 | |
| Air displacement | m ³ /h | 140 | 205 | 315 | 350 | 450 | 605 | 275 | 405 | 635 | 700 | 900 | 1180 | 390 | 610 | 880 | 1050 | 1350 | 1800 | |
| Sound level | dB(A) | 15 | 24 | 33 | 38 | 45 | 51 | 15 | 24 | 34 | 38 | 46 | 51 | 15 | 24 | 34 | 38 | 46 | 51 | |

HEATING

| | | DECO 50 | | | | | | DECO 100 | | | | | | DECO 150 | | | | | | |
|-------------------------------------|-------------------|---------|-----|-----|-------|-----|-----|----------|-----|-----|-------|-----|------|----------|------|------|-------|------|------|---|
| | | HE | | | 400 V | | | HE | | | 400 V | | | HE | | | 400 V | | | |
| | | Speed | 1 | 2 | 3 | 4 | 5 | 6 | 1 | 2 | 3 | 4 | 5 | 6 | 1 | 2 | 3 | 4 | 5 | 6 |
| Air displacement | m ³ /h | 140 | 205 | 315 | 350 | 450 | 605 | 275 | 405 | 635 | 700 | 900 | 1180 | 390 | 610 | 880 | 1050 | 1350 | 1800 | |
| Available heating cap. ¹ | kW | 6.6 | | | | | | 10 | | | | | | 14.8 | | | | | | |
| Max. power consumption per phase | A | 10.1 | | | | | | 15.2 | | | | | | 22.5 | | | | | | |
| Air inlet temperature | °C | -10 | | | | | | -10 | | | | | | -10 | | | | | | |
| Discharge temperature | °C | 50 | 50 | 46 | 41 | 29 | 19 | 50 | 50 | 32 | 28 | 20 | 13 | 50 | 50 | 35 | 28 | 19 | 12 | |
| Real heating capacity | kW | 3.1 | 4.6 | 6.6 | 6.6 | 6.6 | 6.6 | 6.2 | 9.1 | 10 | 10 | 10 | 10 | 8.8 | 13.7 | 14.8 | 14.8 | 14.8 | 14.8 | |
| Air inlet temperature | °C | 0 | | | | | | 0 | | | | | | 0 | | | | | | |
| Discharge temperature | °C | 50 | 50 | 50 | 50 | 41 | 30 | 50 | 50 | 44 | 40 | 31 | 23 | 50 | 50 | 47 | 39 | 30 | 23 | |
| Real heating capacity | kW | 2.5 | 3.7 | 5.7 | 6.3 | 6.6 | 6.6 | 5 | 7.3 | 10 | 10 | 10 | 10 | 7 | 11 | 14.8 | 14.8 | 14.8 | 14.8 | |
| Air inlet temperature | °C | 10 | | | | | | 10 | | | | | | 10 | | | | | | |
| Discharge temperature | °C | 50 | 50 | 50 | 50 | 50 | 42 | 50 | 50 | 50 | 50 | 42 | 34 | 50 | 50 | 50 | 50 | 42 | 34 | |
| Real heating capacity | kW | 1.9 | 2.8 | 4.4 | 4.8 | 6.2 | 6.6 | 3.8 | 5.6 | 8.8 | 9.7 | 10 | 10 | 5.4 | 8.4 | 12.2 | 14.5 | 14.8 | 14.8 | |
| Air inlet temperature | °C | 20 | | | | | | 20 | | | | | | 20 | | | | | | |
| Discharge temperature | °C | 50 | 50 | 50 | 50 | 50 | 50 | 50 | 50 | 50 | 50 | 45 | 45 | 50 | 50 | 50 | 50 | 50 | 45 | |
| Real heating capacity | kW | 1.4 | 2.1 | 3.2 | 3.5 | 4.5 | 6.1 | 2.8 | 4.1 | 6.4 | 7 | 9 | 10 | 3.9 | 6.1 | 8.8 | 10.6 | 13.6 | 14.8 | |

¹ At some fan speeds, the available heating capacity may be higher than the real heating capacity, as the control system limits the outlet air temperature tot 50°C. * The DECO 75 and DECO 125 are not available as electrically heated units.

TECHNICAL EXPLANATION

CORRECTION COEFFICIENTS- HEATING CAPACITY

The heating capacities for the coil types H1 and H2 listed in the tables on pages 8 to 12 are based on a water temperature range of 80/60°C. The heating capacities for the coil type H4 are based on a water temperature range of 50/30°C. If water temperatures differ, the heating capacity is to be multiplied by the coefficients from the below tables. These coefficients are applicable to the heating capacities from the tables on pages 8 to 12 at an inlet air temperature of 20°C. The first table lists the correction coefficients for the coil types H1 and H2. The correction coefficients for the coil type H4 are listed in the second table.

CORRECTION COEFFICIENTS FOR HEATING CAPACITIES OF THE BATTERY TYPES H1 AND H2

| H1/H2 | Air inlet temperature | | | |
|---------|-----------------------|-----|------|------|
| | -10°C | 0°C | 10°C | 20°C |
| 90/70°C | 2 | 1.8 | 1.5 | 1.2 |
| 80/60°C | 1.8 | 1.5 | 1.2 | 1 |
| 70/50°C | 1.5 | 1.3 | 1 | 0.8 |
| 60/40°C | 1.3 | 1 | 0.8 | 0.5 |
| 50/30°C | 1 | 0.8 | 0.5 | 0.3 |

CORRECTION COEFFICIENTS FOR HEATING CAPACITY OF THE BATTERY TYPE H4

| H4 | Air inlet temperature | | | |
|---------|-----------------------|-----|------|------|
| | -10°C | 0°C | 10°C | 20°C |
| 90/70°C | 7.1 | 6.1 | 5.1 | 4.2 |
| 80/60°C | 6.2 | 5.2 | 4.3 | 3.4 |
| 70/50°C | 5.4 | 4.4 | 3.5 | 2.7 |
| 60/40°C | 4.5 | 3.6 | 2.7 | 1.9 |
| 50/30°C | 3.6 | 2.7 | 1.9 | 1 |

EXPLANATION

The correction coefficients are for the capacities listed in the tables on page 8 to 13. They give an indication of the capacity at deviating water temperatures and air conditions. For exact data, please seek the advice of a Biddle employee.

TECHNICAL EXPLANATION

CORRECTION COEFFICIENTS - COOLING CAPACITY

The cooling capacities for the coil types C2, C3 and C4 listed in the tables on pages 8 to 12 are based on a water temperature range of 6/12°C and on an inlet air temperature of 27°C at 48% R.H. If water temperatures and inlet air conditions differ, the cooling capacity is to be multiplied by coefficients from the table below.

CORRECTION FACTORS COOLING CAPACITY COIL TYPES C2, C3 AND C4

| C2, C3 and C4 LPCW | Air inlet temperature | Relative humidity | | | | | |
|-----------------------|-----------------------|-------------------|-------|----------|-------|----------|-------|
| | | 40% R.H. | | 50% R.H. | | 60% R.H. | |
| | | Q_t | Q_v | Q_t | Q_v | Q_t | Q_v |
| 6/12°C | 22°C | 0.8 | 0.9 | 0.8 | 0.9 | 0.9 | 0.8 |
| | 24°C | 1 | 1 | 1 | 1 | 1.3 | 1 |
| | 26°C | 1.2 | 1.2 | 1.3 | 1.1 | 1.7 | 1.1 |
| | 28°C | 1.3 | 1.3 | 1.7 | 1.3 | 2.1 | 1.2 |
| 10/16°C | 22°C | 0.5 | 0.5 | 0.5 | 0.5 | 0.5 | 0.5 |
| | 24°C | 0.7 | 0.7 | 0.7 | 0.7 | 0.7 | 0.7 |
| | 26°C | 0.9 | 0.9 | 0.9 | 0.9 | 0.9 | 0.8 |
| | 28°C | 1 | 1 | 1 | 1 | 1.4 | 1 |
| 12/18°C | 22°C | 0.4 | 0.4 | 0.4 | 0.4 | 0.4 | 0.4 |
| | 24°C | 0.5 | 0.6 | 0.5 | 0.6 | 0.5 | 0.6 |
| | 26°C | 0.6 | 0.7 | 0.6 | 0.7 | 0.6 | 0.7 |
| | 28°C | 0.8 | 0.9 | 0.8 | 0.9 | 1 | 0.8 |

Q_t = total cooling capacity Q_v = sensible cooling capacity.

TECHNICAL EXPLANATION

WATER FLOW RATE

The water flow rates listed in the tables on pages 8 to 12 are based on a water temperature range of 80/60°C or 50/30°C. If water flow rates differ from those listed in the tables on pages 8 to 13, the water flow rate may be roughly calculated using the opposite formula. Before doing so, the heating capacity must first be recalculated (see page 14).

- m_w = water flow rate [l/h]
- Q = capacity [kW]
- c_{pw} = specific heat of water (=4.18) [kJ/kg°C]
- ΔT_w = temperature difference water [°C]
- ρ_w = density of water at 90°C (=0.984) [kg/l]

$$m_w = \frac{Q}{\rho_w c_{pw} \Delta T_w} \cdot 3600 \text{ [l/h]}$$

WATER PRESSURE DROP

All water temperatures differ from those listed in the tables on pages 8 to 12, then the water pressure loss may be roughly calculated using the formula below. To do so, the water flow rate must first be calculated (see left).

- ΔP_{w1} = water pressure loss, table values [kPa]
- ΔP_{w2} = water pressure loss [kPa]
- m_{w1} = water flow rate, table values [l/h]
- m_{w2} = water flow rate calculated using formula [l/h]

$$\Delta P_{w2} = \Delta P_{w1} \left(\frac{m_{w2}}{m_{w1}} \right)^2 \text{ [kPa]}$$

SOUND

In the tables on pages 8 to 13, a sound level in the reverberation field is listed for all six speeds. These sound level values are based on the use of one fan coil unit in a reference room.

REFERENCE ROOM

For each type of fan coil unit, a room has been taken for expressing the noise level. The reference room (V_0) is chosen dependent on the size of the unit, such that the air circulation ratio in the room is equal to 2 at fan speed 4. The reference room is stated in the opposite table. As many offices have sound-absorbing ceilings, an average reverberation time of 0.5 second has been assumed.

| Unit size | Reference room |
|-----------|-------------------|
| DECO 50 | 175m ³ |
| DECO 75 | 258m ³ |
| DECO 100 | 350m ³ |
| DECO 125 | 420m ³ |
| DECO 150 | 525m ³ |

SOUND IN A DEVIATING ROOM AND WITH MULTIPLE UNITS

If a unit is used in a deviating room, or if multiple devices are used in a single room, the sound pressure level must be recalculated. This can be done using the formula below. The relevant table value can be found in the tables (general data).

- L_p = sound pressure [dB(A)]
- T = reverberation time in deviating room [s]
- T_0 = reverberation time [s] (see table)
- V = volume deviating room [m³]
- V_0 = volume reference room [m³] (see table)
- n = number of units

$$L_p = \text{table value} + \left(10 \cdot \log \left(\frac{T}{T_0} \right) - 10 \cdot \log \left(\frac{V}{V_0} \right) + 10 \cdot \log (n) \right) \text{ [dB(A)]}$$

Sample calculation: Wanted: the noise level in the reverberation field if three DECO 75 fan coil units are used at speed 3 in a room featuring a reverberation time of 0.6 second and a volume of 600m³.

$$34 + \left(10 \cdot \log \left(\frac{0.6}{0.5} \right) - 10 \cdot \log \left(\frac{600}{258} \right) + 10 \cdot \log (3) \right)$$

$$= 34 + (0.8 - 3.7 + 4.8) = 35,9 \text{ dB(A)}$$

TECHNICAL EXPLANATION

OVERVIEW OF SOUND DATA

| Unit size | | Sound pressure level* | Sound power level** | | | | | | | | |
|-----------|-------|-----------------------|---------------------|---|--------|--------|---------|---------|---------|---------|------|
| Type | Speed | | in dB(A) | Per octave band in the medium frequency in dB (ref 1 x 10 ⁻¹² W) | | | | | | | |
| | | Lp | 63 Hz | 125 Hz | 250 Hz | 500 Hz | 1000 Hz | 2000 Hz | 4000 Hz | 8000 Hz | Lw |
| DECO 50 | 1 | 15 | 30.3 | 32.4 | 30.7 | 25.4 | 16.3 | 8.9 | 0 | 0 | 26.3 |
| | 2 | 23.8 | 33.7 | 39.7 | 37.4 | 34.5 | 28.6 | 23.7 | 10.3 | 0 | 35.3 |
| | 3 | 33.3 | 38.9 | 47.5 | 44.5 | 43.1 | 39.2 | 6.9 | 25.9 | 14.5 | 44.8 |
| | 4 | 37.9 | 41.5 | 51.6 | 48.5 | 46.6 | 44.2 | 42.4 | 33.5 | 23 | 49.4 |
| | 5 | 45.4 | 47.2 | 58.1 | 55 | 53.1 | 51.2 | 50.9 | 45 | 36.1 | 56.9 |
| | 6 | 50.6 | 51.2 | 62.6 | 60 | 57.6 | 56.7 | 55.9 | 51.5 | 44.1 | 62.1 |
| DECO 75 | 1 | 14.1 | 34.1 | 33.8 | 29.7 | 27.6 | 15.4 | 11.7 | 0 | 0 | 27.2 |
| | 2 | 26.5 | 40.5 | 42.3 | 44.5 | 38.5 | 30.1 | 23.7 | 12 | 0 | 39.6 |
| | 3 | 34 | 45.8 | 48.9 | 45.5 | 46.6 | 41.7 | 36.9 | 27.4 | 12.2 | 47 |
| | 4 | 38.6 | 47.9 | 53.4 | 50 | 50.6 | 46.7 | 42.4 | 35 | 21.4 | 51.7 |
| | 5 | 46.2 | 53.5 | 59.9 | 56 | 57.1 | 54.7 | 51.4 | 46 | 34.5 | 59.3 |
| | 6 | 50.8 | 58 | 64.9 | 61 | 61.1 | 58.7 | 56.9 | 52 | 43 | 63.9 |
| DECO 100 | 1 | 14.8 | 35.6 | 35.1 | 32.2 | 29.4 | 19.8 | 12.4 | 0.8 | 0 | 29.3 |
| | 2 | 24.1 | 39.1 | 42.4 | 38.9 | 38.5 | 32.1 | 27.2 | 13.3 | 1.6 | 38.6 |
| | 3 | 33.7 | 44.2 | 50.2 | 46 | 47.1 | 42.7 | 40.4 | 28.9 | 18.1 | 48.2 |
| | 4 | 38.3 | 46.9 | 54.2 | 50 | 50.6 | 47.7 | 45.9 | 36.5 | 26.6 | 52.8 |
| | 5 | 45.8 | 52.5 | 60.7 | 56.5 | 57.1 | 54.7 | 54.4 | 48 | 39.6 | 60.3 |
| | 6 | 51 | 56.5 | 65.2 | 61.5 | 61.6 | 60.2 | 59.4 | 54.5 | 47.6 | 65.5 |
| DECO 125 | 1 | 13.7 | 35.7 | 34.9 | 30.5 | 29.6 | 19.7 | 10.4 | 0 | 0 | 29 |
| | 2 | 23.4 | 39.7 | 42.3 | 40.9 | 39 | 30.8 | 23.9 | 9 | 0 | 38.7 |
| | 3 | 31.8 | 43.3 | 49.3 | 46 | 46.1 | 42.2 | 37.3 | 25.8 | 13.6 | 47.1 |
| | 4 | 36.8 | 46.5 | 52.9 | 50.5 | 50.6 | 47.2 | 43.9 | 34 | 20.6 | 52.1 |
| | 5 | 45 | 51.7 | 59.9 | 57 | 57.1 | 55.7 | 53.4 | 47 | 36.1 | 60.3 |
| | 6 | 51.4 | 56.7 | 66.4 | 62.5 | 63.1 | 61.7 | 60.4 | 55 | 46.6 | 66.7 |
| DECO 150 | 1 | 15 | 36.9 | 37.3 | 33.7 | 31.4 | 21.3 | 13.9 | 2.9 | 0 | 31.2 |
| | 2 | 24.2 | 40.4 | 44.6 | 40.4 | 40.5 | 33.6 | 28.7 | 15.3 | 2.2 | 40.4 |
| | 3 | 33.8 | 45.5 | 52.4 | 47.5 | 49.1 | 44.2 | 41.9 | 30.9 | 18.6 | 50 |
| | 4 | 38.3 | 48.2 | 56.4 | 51.5 | 52.6 | 49.2 | 47.4 | 38.5 | 27.1 | 54.5 |
| | 5 | 45.8 | 53.8 | 62.9 | 58 | 59.1 | 56.2 | 55.9 | 50 | 40.1 | 62 |
| | 6 | 51 | 57.8 | 67.4 | 63 | 63.6 | 61.7 | 60.9 | 56.5 | 48.2 | 67.2 |

* The noise levels are based on the reverberation field in a reference room (see page 16).

** The value <0 indicates that the relevant value is below the threshold of hearing.

TECHNICAL EXPLANATION

SOUND-DAMPING AIR INLET SECTION

To reduce the noise, a sound-damping air inlet section can be installed in units that feature outside-air inlet. The section reduces both the outside noise coming in, such as traffic noise, and the inside noise going out, such as bar noise. The inner side of the sound-damping inlet section is finished with a sound-absorbing open-cell foam coat. The sound damping values have been measured according to NEN 20140 at the laboratory of the Groningen-based firm Van Dorsser BV (The Netherlands).

DAMPING VALUE - SOUND POWER LEVEL [DB]

| Mode | Dn*, referenced to 10m ² | | | | | | Total LW |
|---------------------------------------|---|-------|-------|--------|--------|--------|-------------|
| | Per octave band in the medium frequency | | | | | | |
| | 125Hz | 250Hz | 500Hz | 1000Hz | 2000Hz | 4000Hz | |
| Damper actuator in ventilation mode | 25 | 21 | 28 | 36 | 37 | 48 | 29 |
| Damper actuator in recirculation mode | 24 | 23 | 33 | 37 | 37 | 49 | 31 |

* Dn is damping valve

DAMPING VALUE - SOUND LEVEL DIFFERENTIAL PER OCTAVE

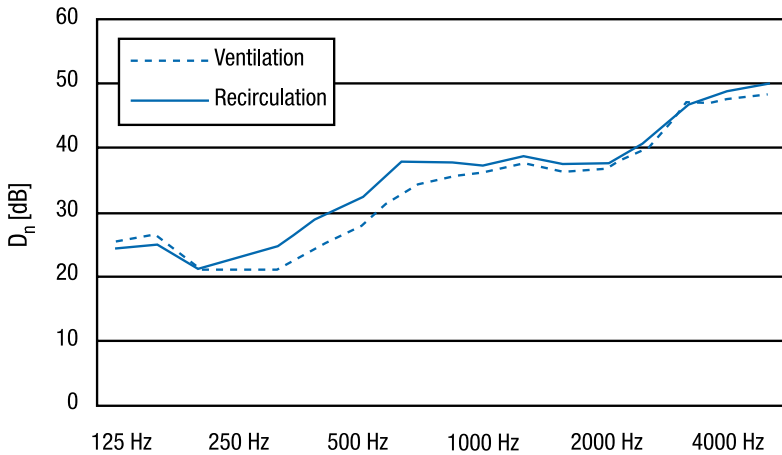

The values from the table below can be used for a simplified calculation.

DAMPING VALUE - SOUND POWER LEVEL [DB(A)]











| Mode | $R_{A,netto}$ * | | | | |
|---------------------------------------|-----------------|---------|----------|----------|----------|
| | DECO 50 | DECO 75 | DECO 100 | DECO 125 | DECO 150 |
| Damper actuator in ventilation mode | 6 | 8 | 10 | 11 | 11 |
| Damper actuator in recirculation mode | 8 | 10 | 12 | 13 | 13 |
| Wall duct [m ²] | 0.061 | 0.093 | 0.12 | 0.16 | 0.19 |

* $R_{A,netto}$ is the sound reduction per type of sound-damping air inlet section.

TECHNICAL EXPLANATION

DIMENSIONAL SKETCHES OF STYLISH MODEL (S)

Depicted model DECO 50-HIC3-R-FS10

| Recirculation | Ventilation | Recirculation/ Ventilation |
|---|---|--|
|  FS2 |  FS6 |  FS8 |
|  FS10 |  FS12 | |
|  CS2 |  CS6 |  CS8 |
|  CS10 |  CS12 | |

See page 4, figure 1.

△ = inspection side → = air direction

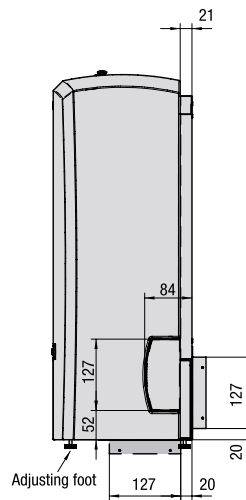
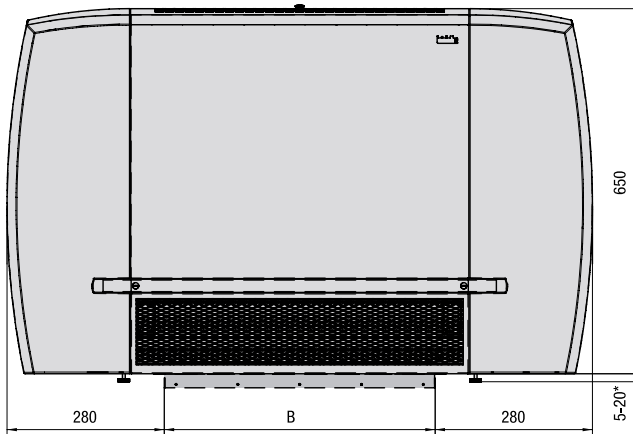
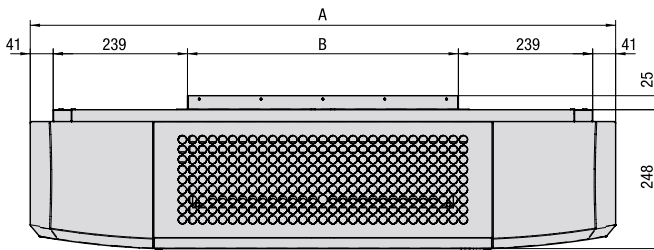
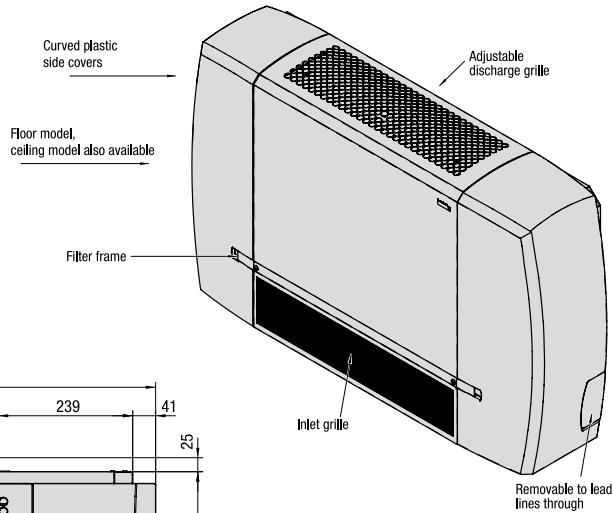

| Unit size | A | B |
|-----------|------|------|
| DECO 50 | 1042 | 482 |
| DECO 75 | 1292 | 732 |
| DECO 100 | 1542 | 982 |
| DECO 125 | 1792 | 1232 |
| DECO 150 | 2042 | 1482 |

All dimensions in mm. *Adjusting size for adjusting feet. Only the floor model comes with adjusting feet.

TECHNICAL EXPLANATION

DIMENSIONAL SKETCHES OF BUSINESS MODEL (B)

Depicted model DECO 50-HIC3-R-FB10

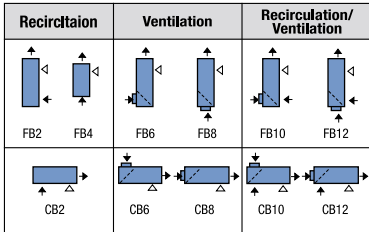

See page 4, figure 1.

△ = inspection side → = air direction

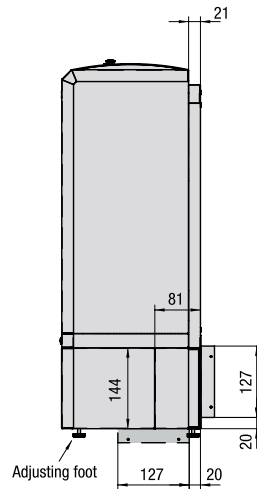
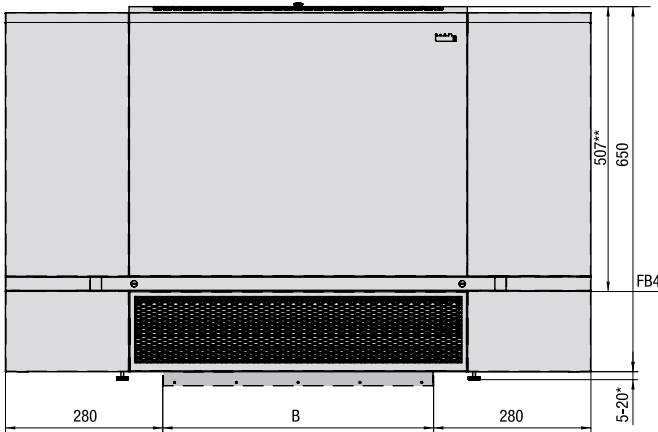
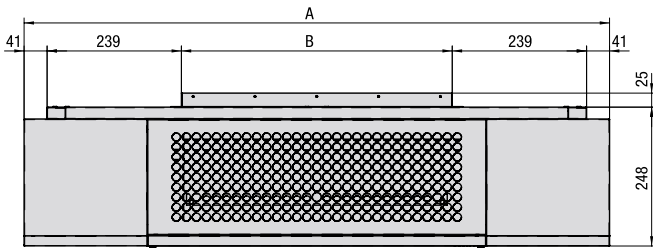
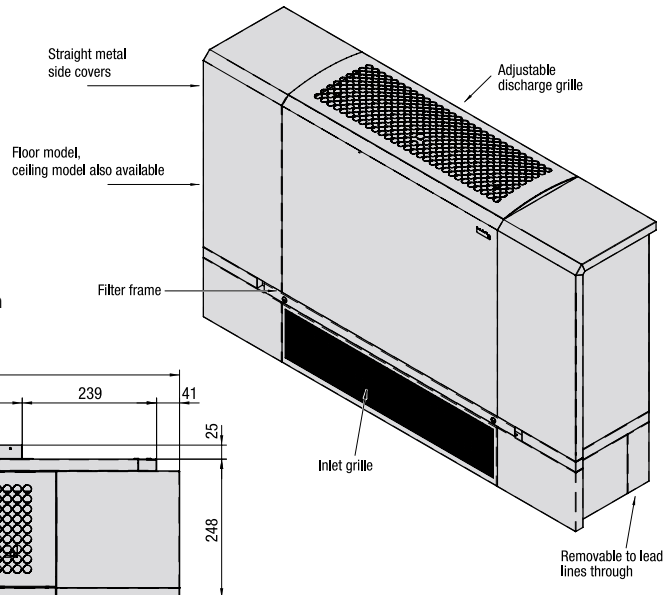

| Unit size | A | B |
|-----------|------|------|
| DECO 50 | 1042 | 482 |
| DECO 75 | 1292 | 732 |
| DECO 100 | 1542 | 982 |
| DECO 125 | 1792 | 1232 |
| DECO 150 | 2042 | 1482 |

All dimensions in mm. *Adjusting size for adjusting feet. Only the floor model comes with adjusting feet.

**Applies only for encased floor model for recirculation, type FB4. The minimum distance between floor and unit will then be 120mm.

TECHNICAL EXPLANATION

DIMENSIONAL SKETCHES OF RECESSED MODEL (R)

Depicted model DECO 50-HIC3-L-FR10

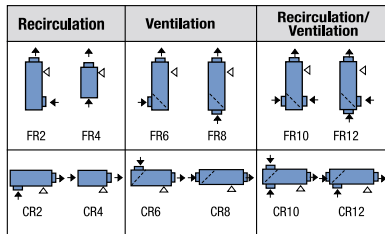

See page 4, figure 1.

△ = inspection side → = air direction

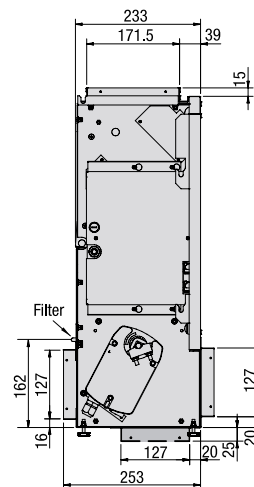
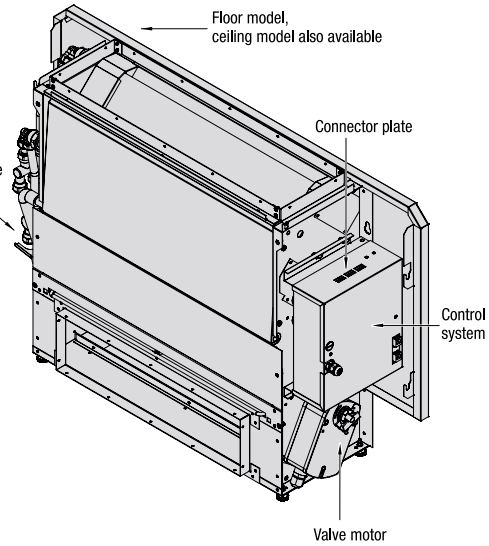
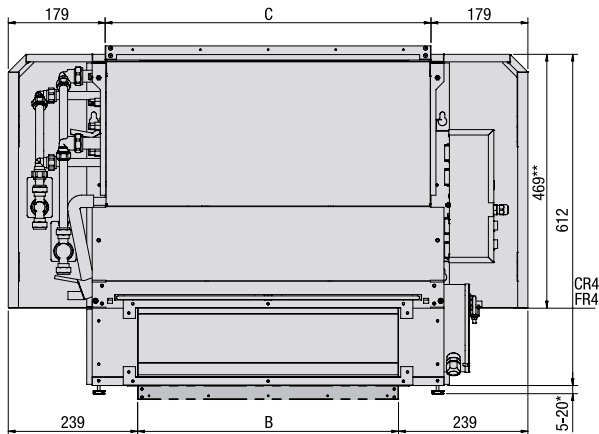
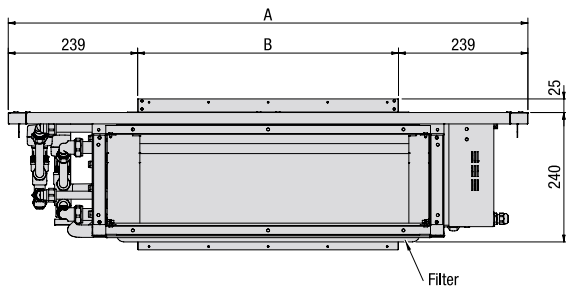

| Unit size | A | B | C |
|-----------|------|------|------|
| DECO 50 | 960 | 482 | 602 |
| DECO 75 | 1210 | 732 | 852 |
| DECO 100 | 1460 | 982 | 1102 |
| DECO 125 | 1710 | 1232 | 1352 |
| DECO 150 | 1960 | 1482 | 1602 |

All dimensions in mm. *Adjusting size for adjusting feet. Only the floor model comes with adjusting feet.

**Applies only for recessed models for recirculation, types FR4 and CR4. The minimum distance between floor and unit will then be 120mm.

TECHNICAL EXPLANATION

DIMENSIONAL SKETCHES WATER CONNECTIONS

Depicted model DECO 50-HIC3-L-FR6

| Unit size | A |
|-----------|------|
| DECO 50 | 644 |
| DECO 75 | 894 |
| DECO 100 | 1144 |
| DECO 125 | 1394 |
| DECO 150 | 1644 |

| Coil types | B | C |
|------------|-----|-----|
| H1, H2, C2 | - | 116 |
| C3 | - | 124 |
| H4, C4 | - | 133 |
| HIC3 | 113 | 130 |

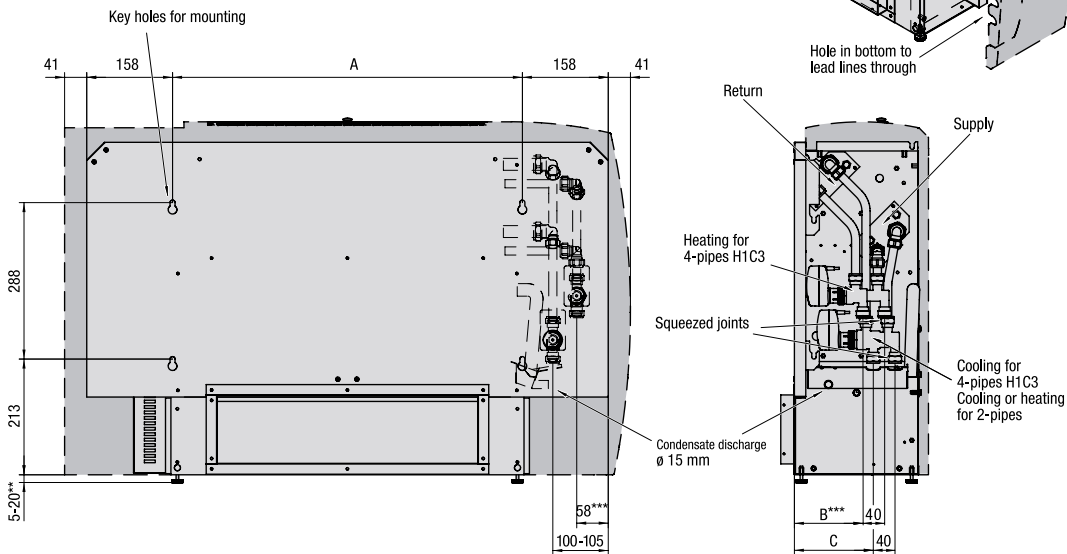
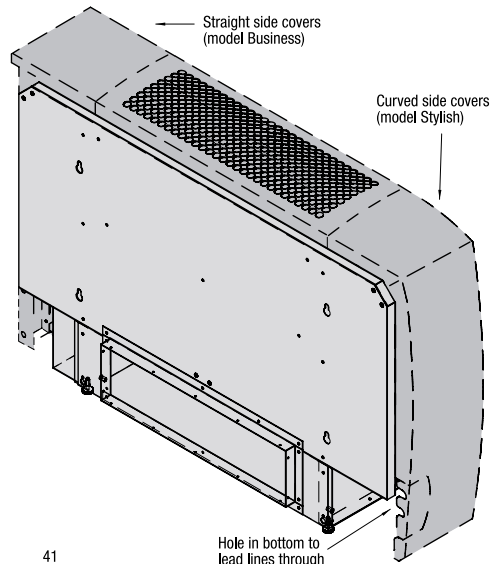

| Unit size | Coil types | | | | | | | | | | | |
|-----------|------------|----|-------|----|-------|----|-------|----|-------|----|-------|----|
| | H1 | | H2 | | H4 | | C2 | | C3 | | C4 | |
| | Kvs* | ø | Kvs* | ø | Kvs* | ø | Kvs* | ø | Kvs* | ø | Kvs* | ø |
| DECO 50 | 1 | 15 | 1,6 | 15 | 2,5 | 22 | 1,6 | 15 | 2,5 | 22 | 2,5 | 22 |
| DECO 75 | 1 | 15 | 1,6 | 15 | 2,5 | 22 | 1,6 | 15 | 2,5 | 22 | 2,5 | 22 |
| DECO 100 | 1,6 | 15 | 4/3,5 | 22 | 4/3,5 | 22 | 4/3,5 | 22 | 4/3,5 | 22 | 4/3,5 | 22 |
| DECO 125 | 1,6 | 15 | 4/3,5 | 22 | 4/3,5 | 22 | 4/3,5 | 22 | 4/3,5 | 22 | 4/3,5 | 22 |
| DECO 150 | 1,6 | 15 | 4/3,5 | 22 | 4/3,5 | 22 | 4/3,5 | 22 | 4/3,5 | 22 | 4/3,5 | 22 |

All dimensions in mm. With sizes B and C, minor deviations of 5mm at the most may occur.

* Kvs values for 3- and 2-way valves. Where values vary, the 3-way valve is mentioned first, followed by the 2-way valve.

** Adjusting size for adjusting feet. Only the floor model comes with adjusting feet.

*** Size for H1-connection if HIC3 is used.

- pipe diameter squeezed joint DN 15: 15 mm, DN 20: 22 mm.

- pipe connection can be made to both the left- and the right-hand side of the unit.

TECHNICAL EXPLANATION

DIMENSIONAL SKETCHES OF ATTENUATED AIR INLET SECTION

Depicted DECO 50

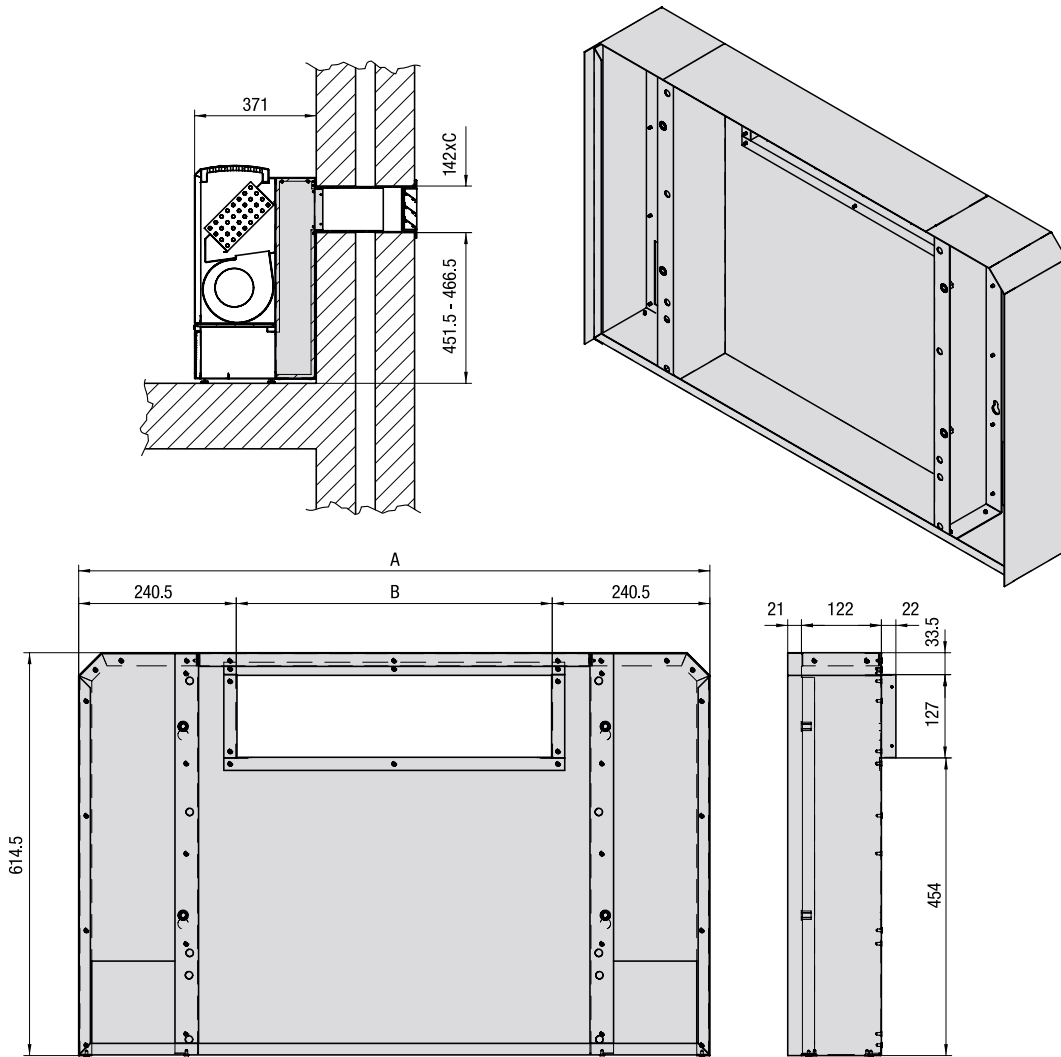

| Unit size | A | B | C |
|-----------|------|------|------|
| DECO 50 | 963 | 482 | 503 |
| DECO 75 | 1213 | 732 | 753 |
| DECO 100 | 1463 | 982 | 1003 |
| DECO 125 | 1713 | 1232 | 1253 |
| DECO 150 | 1963 | 1482 | 1503 |

All dimensions in mm. Available for Ceiling and Wall models. Holes for mounting are situated at the back site of the unit (see page 22).

TECHNICAL EXPLANATION

DIMENSIONAL SKETCHES DISCHARGE SECTION AND PLENUM

Depicted DECO 50-H1C3-L-FR10

DISCHARGE SECTION*

Material: zinc coated plate steel

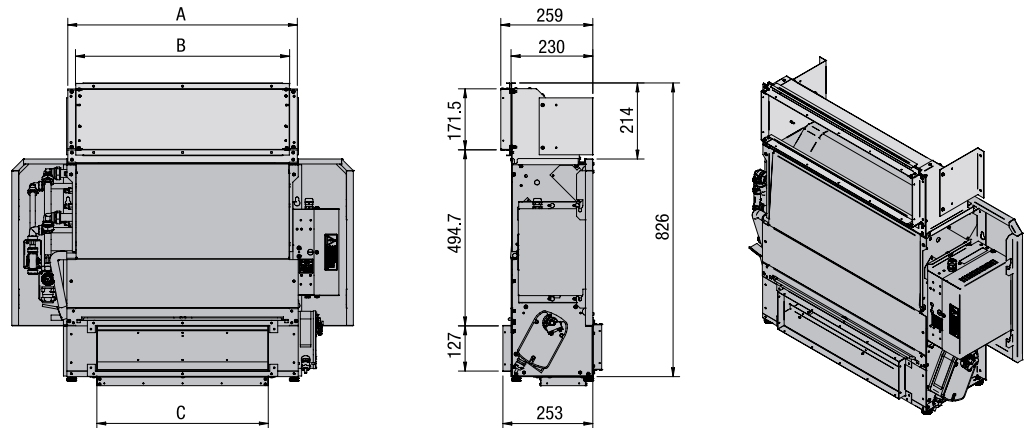

| Unit size | A | B | C |
|-----------|------|------|------|
| DECO 50 | 645 | 602 | 482 |
| DECO 75 | 895 | 852 | 732 |
| DECO 100 | 1145 | 1102 | 982 |
| DECO 125 | 1395 | 1352 | 1232 |
| DECO 150 | 1645 | 1602 | 1482 |

AIR INLET AND DISCHARGE PLENUM

Material: zinc coated plate steel

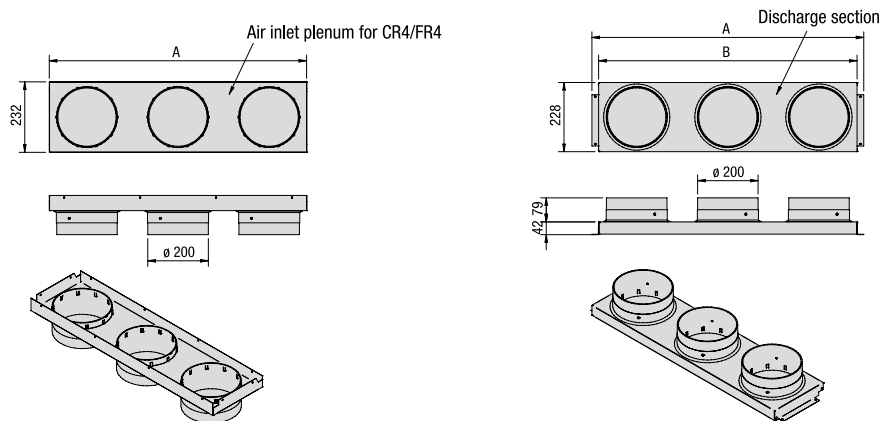

| Air inlet plenum for FRC/CR4 | | | |
|------------------------------|------|--------|-----|
| Unit size | A | Spouts | C |
| DECO 50 | 597 | 2 | 300 |
| DECO 75 | 847 | 3 | 300 |
| DECO 100 | 1097 | 4 | 270 |
| DECO 125 | 1347 | 5 | 275 |
| DECO 150 | 1597 | 6 | 265 |

| Discharge plenum | | | | |
|------------------|------|------|--------|-----|
| Unit size | A | B | Spouts | C |
| DECO 50 | 645 | 601 | 2 | 300 |
| DECO 75 | 895 | 851 | 3 | 300 |
| DECO 100 | 1145 | 1101 | 4 | 270 |
| DECO 125 | 1395 | 1351 | 5 | 275 |
| DECO 150 | 1645 | 1601 | 6 | 265 |

All dimensions are in mm. *The discharge section is used in recessed models to switch from top discharge to front discharge.
* The discharge section may be used with a flexible connection sleeve (see page 26) or a grille (page 26).

TECHNICAL EXPLANATION

DIMENSIONAL SKETCHES FLEXIBLE CONNECTION SLEEVES

Depicted DECO 50-H1C3-L-FR10

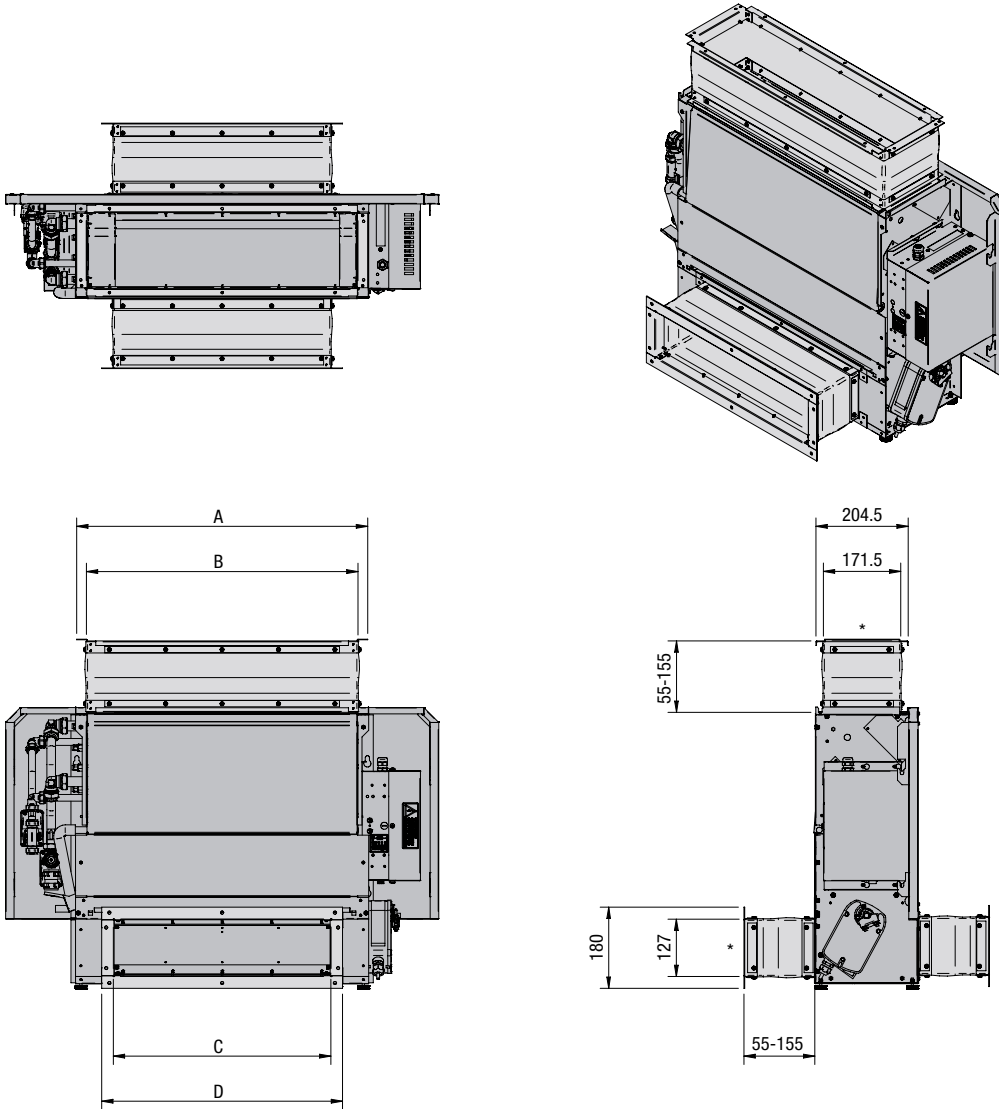

| Unit size | A | B | C | D |
|-----------|------|------|------|------|
| DECO 50 | 645 | 602 | 482 | 534 |
| DECO 75 | 895 | 852 | 732 | 784 |
| DECO 100 | 1145 | 1102 | 982 | 1034 |
| DECO 125 | 1395 | 1352 | 1232 | 1284 |
| DECO 150 | 1645 | 1602 | 1482 | 1534 |

All dimensions in mm. Material: PVC-coated polyester tissue (bisonyl)

* Available with or without duct connection flange (made of zinc plated sheet steel). Connection sleeves are delivered unit-mounted.

TECHNICAL EXPLANATION

DIMENSIONAL SKETCHES OF WALL AND CEILING GRILLES

Depicted for model DECO 50

ADJUSTABLE DISCHARGE GRILLE

Material: painted zinc plated sheet steel

| Unit size | A | B | C |
|-----------|------|------|------|
| DECO 50 | 645 | 623 | 602 |
| DECO 75 | 895 | 873 | 852 |
| DECO 100 | 1145 | 1123 | 1102 |
| DECO 125 | 1395 | 1373 | 1352 |
| DECO 150 | 1645 | 1623 | 1602 |

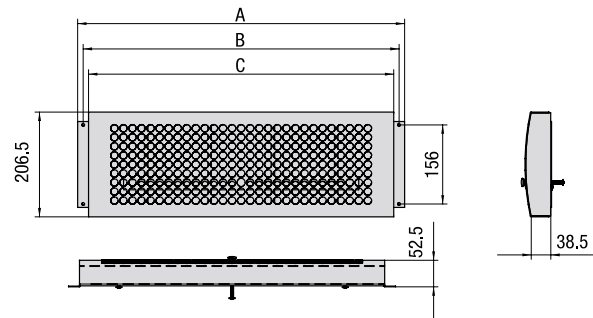

FIN GRILLES

Material: natural-coloured, extruded, anodised aluminium, includes a fixing frame with recessed holes. Available in three types:

| Double adjustable grille | | |
|--------------------------|------|------|
| Unit size | A | B |
| DECO 50 | 515 | 469 |
| DECO 75 | 765 | 719 |
| DECO 100 | 1015 | 969 |
| DECO 125 | 1265 | 1219 |
| DECO 150 | 1515 | 1469 |

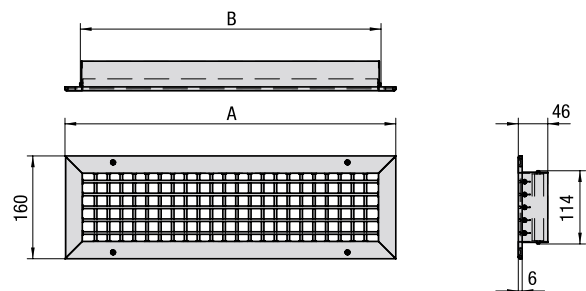

| Single adjustable grille | | |
|--------------------------|------|------|
| Unit size | A | B |
| DECO 50 | 515 | 469 |
| DECO 75 | 765 | 719 |
| DECO 100 | 1015 | 969 |
| DECO 125 | 1265 | 1219 |
| DECO 150 | 1515 | 1469 |

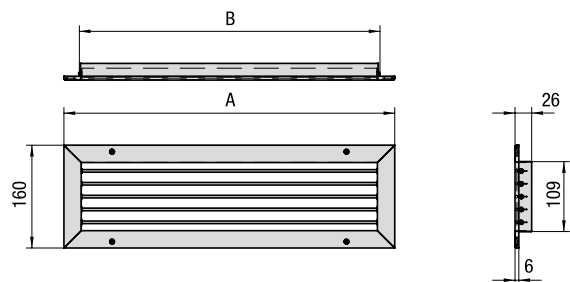

| Fixed grille | | |
|--------------|------|------|
| Unit size | A | B |
| DECO 50 | 528 | 477 |
| DECO 75 | 778 | 727 |
| DECO 100 | 1028 | 977 |
| DECO 125 | 1278 | 1227 |
| DECO 150 | 1528 | 1477 |

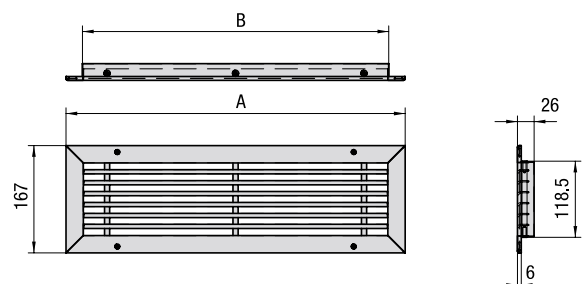

All dimensions in mm.

These grilles can be used for both in- and outlet sides. On the outlet side, the grille is mounted onto the unit using a flange.

TECHNICAL EXPLANATION

DIMENSIONAL SKETCHES WALL AND ROOF DUCTS

Depicted model DECO 50

ROOF CAP AND ROOF DUCT

Material: 1.5 mm aluminium sheet

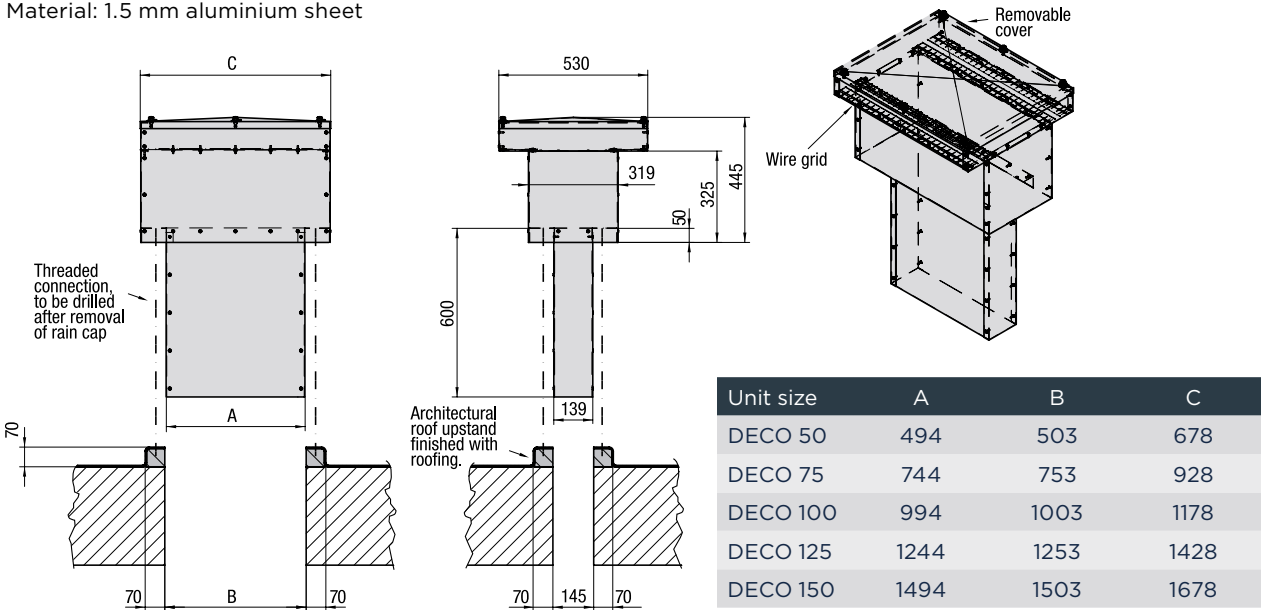

All dimensions in mm.

WALL DUCT AND WALL GRATE

Material: zinc coated plate steel

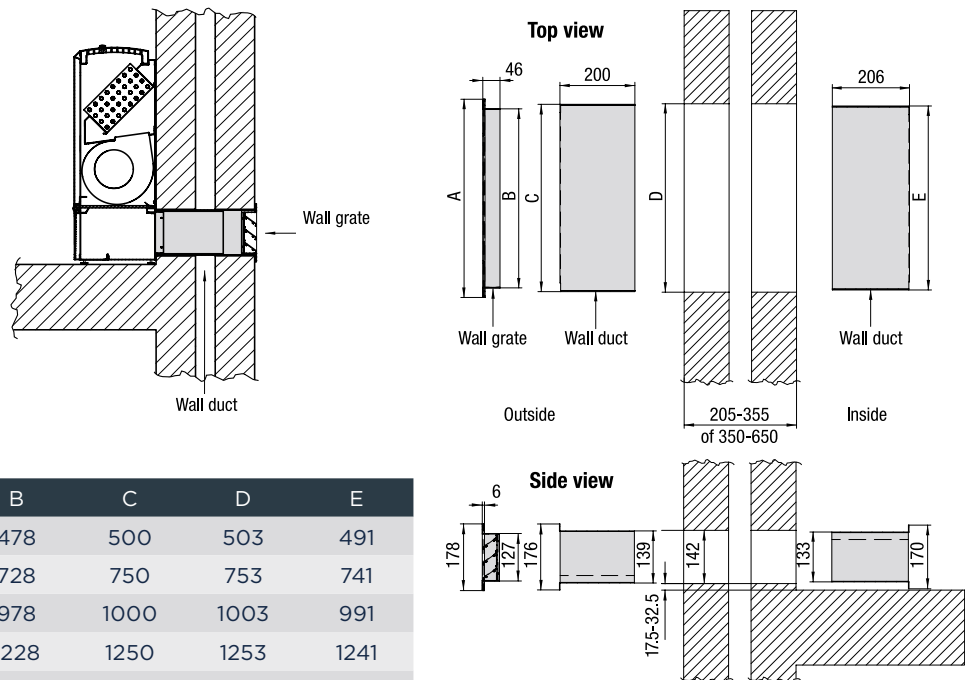

All dimensions in mm.

BIDDLE AIR SYSTEMS

St. Mary's Road
Nuneaton
Warwickshire
CV11 5AU

T +44 (0) 2476 384 233
E sales@biddle-air.co.uk
www.biddle-air.co.uk



Biddle

Every effort has been made to ensure descriptions are correct at the time of print.
Errors and omissions excepted. DECO|V1|08|2019